

**NFPA<sup>®</sup>**

# 225

---

Model Manufactured  
Home Installation  
Standard

---

**2021**



Copyright © 2020 National Fire Protection Association®. All Rights Reserved.

## NFPA® 225

# Model Manufactured Home Installation Standard

### 2021 Edition

This edition of NFPA 225, *Model Manufactured Home Installation Standard*, was prepared by the Technical Committee on Manufactured Housing. It was issued by the Standards Council on October 5, 2020, with an effective date of October 25, 2020, and supersedes all previous editions.

This edition of NFPA 225 was approved as an American National Standard on October 25, 2020.

### Origin and Development of NFPA 225

The first edition of NFPA 225 was developed as a result of numerous actions that led to NFPA being further involved in manufactured housing regulatory issues. First, it should be noted that the previous responsibility for management of the ANSI standard for this subject was with the National Conference of States on Building Codes and Standards (NCSBCS). Their 1994 document, NCSBCS A 225.1, *Manufactured Home Installations*, formed the basis for the first edition of NFPA 225. In 2000, an agreement in principle was reached between NCSBCS and NFPA that would allow transfer of the ANSI standard to NFPA. It was a logical move, since an installation standard would use the basic criteria of the manufactured housing standard, as contained in NFPA 501, *Standard on Manufactured Housing*, for a completed unit to be efficiently, effectively, safely, and adequately installed.

The second area that highlighted the need for the installation standard was passage of the Manufactured Housing Improvement Act (MHIA) of 2000. Although the MHIA was not implemented until 2001, the act established a broad set of criteria to ensure that changes could be effectively promulgated with respect to the design, construction, and installation of the stock of manufactured homes. A key provision of the MHIA was the need to establish an installation standard that could be utilized by the U.S. Department of Housing and Urban Development (HUD), the ultimate overseer of manufactured homes. Thus, not only was NFPA 225 developed to pick up where that previous NCSBCS document had left off, it became an integral part of providing another option, along with other state-sponsored installation standards, that could potentially be considered by HUD.

The installation criteria in this standard are widely varied and cover a range of subjects. As written, NFPA 225 is intended to be applied to new installations, regardless of whether they are at new or existing manufactured housing sites. These criteria are intended to be adopted and enforced by the authority having jurisdiction when an alternative state or federal installation standard does not exist.

In addition to covering the basic administrative features and criteria, provisions are included for site preparation work, foundations, and procedures during on-site installation or erection, as well as management of appliances and utility connections. Requirements reflecting current design loads and practices associated with seismic, wind, and flood events have been included. These provisions govern single-section as well as multisection homes and provide requirements for everything from interconnection criteria for multisection homes to anchor provisions to restrict movement from wind loads, seismic events, and floods.

The 2009 edition added extensive revisions to the ground anchor design and spacing criteria. These revisions included the addition of more detail concerning soil conditions, width of the unit being installed, and anticipated loading on the home. An entirely new chapter, Chapter 15, outlined a design approach for prescriptive flood design provisions. These changes allowed the 2009 edition of NFPA 225 to align more closely with the requirements of FEMA's flood-resistant design criteria and the 2005 edition of ASCE/SEI 7, *Minimum Design Loads for Buildings and Other Structures*.

The 2013 edition included a new section on retroactivity in Chapter 1, and a new provision requiring carbon monoxide detectors was added to align with the requirements for other residential occupancies. Also, the lists of publications in Chapter 2 and Annex E were updated.

The 2017 edition included the following changes:

- (1) The 2013 standard provided guidance on smoke alarms and carbon monoxide detectors but was silent on how fire sprinkler systems should be dealt with during the installation process. For the 2017 edition, language was added to ensure that the installer is provided with the necessary information from the manufacturer to accomplish the connection of the fire sprinkler system and system inspection so the system performs as the codes and standards intend.
- (2) In Section 11.2, the committee removed the word *approved* as being beyond the scope of this document.
- (3) Because ASCE 24, *Flood Resistant Design and Construction*, was revised and republished in 2014, 12.4.2.2.1 clarified which item refers to non-engineered flood openings, revised the referenced section number to match the 2014 edition of ASCE 24, and also clarified which item refers to engineered flood openings.
- (4) Referenced publications were updated as appropriate.

The 2021 edition includes changes to the following:

- (1) A revision to the scope in Section 1.1 to widen the use of the document outside the United States
- (2) A new definition of *dwelling unit*, as extracted from NFPA 101®, *Life Safety Code*®
- (3) A new section in Chapter 7 on interior finish requirements from NFPA 286
- (4) Removal of the requirement for water mist systems and the reference to NFPA 750 in Chapter 10
- (5) Updates to referenced publications and NFPA extracts

## Technical Committee on Manufactured Housing

**Stanley C. Harbuck**, *Chair*  
 School of Building Inspection, MA [C]  
 Rep. American Public Health Association

**Fred Benn**, Advanced Automatic Sprinkler, Inc., CA [M]  
 Rep. National Fire Sprinkler Association

**David G. Bueche**, Hoover Treated Wood Products, CO [M]

**Dean C. Hunter**, Minnesota Department of Labor and Industry, MN [E]

Rep. International Association of Electrical Inspectors

**Christopher P. Jones**, Christopher P. Jones & Associates, NC [E]  
 Rep. FEMA/Mitigation Division

**John V. Loscheider**, Loscheider Engineering Company, WA [U]  
 Rep. Building Seismic Safety Council/Code Resource Support Committee

**Ty J. Maltbie**, Viega LLC, KS [M]

**Robert Parks**, Healthy Homes of Louisiana, LA [SE]

**Bruce J. Swiecicki**, National Propane Gas Association, IL [IM]

**Larry J. Tanner**, Texas Tech University, NW Debris Impact Facility, TX [RT]

### Alternates

**David C. Delaquila**, Aquila Consulting LLC, OH [IM]  
 (Alt. to Bruce J. Swiecicki)

**L. Keith Lofland**, International Association of Electrical Inspectors (IAEI), TX [E]  
 (Alt. to Dean C. Hunter)

**Kevin Carr**, NFPA Staff Liaison

**David K. Low**, DK Low & Associates, LLC, VA [E]  
 (Alt. to Christopher P. Jones)

**Jake Pauls**, Jake Pauls Consulting Services, Canada [C]  
 (Alt. to Stanley C. Harbuck)

*This list represents the membership at the time the Committee was balloted on the final text of this edition. Since that time, changes in the membership may have occurred. A key to classifications is found at the back of the document.*

**NOTE:** Membership on a committee shall not in and of itself constitute an endorsement of the Association or any document developed by the committee on which the member serves.

**Committee Scope:** This Committee shall have primary responsibility for documents on manufactured homes including the installation, sites and communities, and the maintenance of and improvements for existing manufactured homes.

## Contents

|  |         |  |         |
|--|---------|--|---------|
| <b>Chapter 1 Administration</b> .....                                  | 225- 6  | 8.9 Telephone and Cable TV .....   | 225- 34 |
| 1.1 Scope .....  | 225- 6  | 8.10 Joints and Seams .....  | 225- 34 |
| 1.2 Purpose. (Reserved) .....  | 225- 6  | <b>Chapter 9 Preparation of Appliances</b> .....   | 225- 34 |
| 1.3 Application .....  | 225- 6  | 9.1 Clothes Dryer Vent .....   | 225- 34 |
| 1.4 Retroactivity .....  | 225- 6  | 9.2 Comfort Cooling Systems .....  | 225- 34 |
| 1.5 Term Use .....   | 225- 6  | 9.3 Fireplace and Wood-Stove Chimneys and Air<br>Inlets .....                                | 225- 35 |
| 1.6 Equivalency .....  | 225- 7  | 9.4 Range, Cooktop, and Oven Venting .....   | 225- 35 |
| <b>Chapter 2 Referenced Publications</b> .....                         | 225- 7  | 9.5 Flood Hazard Areas .....   | 225- 35 |
| 2.1 General .....  | 225- 7  | 9.6 Seismic Design Categories D <sub>0</sub> , D <sub>1</sub> , D <sub>2</sub> , and E ..... | 225- 35 |
| 2.2 NFPA Publications .....  | 225- 7  | <b>Chapter 10 Utility System Connection and Testing</b> .....                                | 225- 36 |
| 2.3 Other Publications .....   | 225- 7  | 10.1 Proper Procedures .....   | 225- 36 |
| 2.4 References for Extracts in Mandatory Sections .....                | 225- 8  | 10.2 Water Supply .....  | 225- 36 |
| <b>Chapter 3 Definitions</b> .....                                     | 225- 8  | 10.3 Drainage System .....   | 225- 37 |
| 3.1 General .....  | 225- 8  | 10.4 Gas Supply .....  | 225- 37 |
| 3.2 NFPA Official Definitions .....                                    | 225- 8  | 10.5 Heating Oil Systems .....   | 225- 38 |
| 3.3 General Definitions .....  | 225- 8  | 10.6 Electricity .....   | 225- 38 |
| <b>Chapter 4 General</b> .....   | 225- 10 | <b>Chapter 11 Life Safety Features</b> .....   | 225- 39 |
| 4.1 Preinstallation Considerations .....                               | 225- 10 | 11.1 Smoke Alarms .....  | 225- 39 |
| 4.2 Alterations .....  | 225- 10 | 11.2 Fire Sprinkler Systems .....  | 225- 39 |
| 4.3 Data Plate .....   | 225- 10 | 11.3 Carbon Monoxide Detectors .....   | 225- 39 |
| 4.4 Installation Considerations .....                                  | 225- 10 | 11.4 Fire Separation Distances .....   | 225- 39 |
| 4.5 Design and Construction .....                                      | 225- 10 | <b>Chapter 12 Installation in Flood Hazard Areas</b> .....                                   | 225- 39 |
| <b>Chapter 5 Site Preparation</b> .....                                | 225- 14 | 12.1 General .....   | 225- 39 |
| 5.1 Access for Transporter .....                                       | 225- 14 | 12.2 Lowest Floor Elevation .....  | 225- 40 |
| 5.2 Encroachments and Setback Distances .....                          | 225- 14 | 12.3 Foundations and Anchoring .....   | 225- 40 |
| 5.3 Fire Separation Distance .....                                     | 225- 14 | 12.4 Installation Procedures .....   | 225- 40 |
| 5.4 Issuance of Permits .....  | 225- 14 | 12.5 Post-Installation Considerations .....  | 225- 41 |
| 5.5 Site Preparation .....   | 225- 14 | 12.6 Preparation of Appliances .....   | 225- 41 |
| 5.6 Investigation and Bearing Capacity of Soil .....                   | 225- 14 | 12.7 Utility Systems .....   | 225- 41 |
| 5.7 Drainage .....   | 225- 14 | <b>Chapter 13 Seismic Provisions for Prescriptive Design<br/>of Support Systems</b> .....    | 225- 41 |
| 5.8 Ground Moisture Control .....                                      | 225- 15 | 13.1 Scope .....   | 225- 41 |
| <b>Chapter 6 Foundations</b> .....                                     | 225- 15 | 13.2 Minimum Prescriptive Support System<br>Requirements .....                               | 225- 42 |
| 6.1 General .....  | 225- 15 | 13.3 Prescriptive Pier Support Systems .....   | 225- 42 |
| 6.2 Piers .....  | 225- 15 | 13.4 Prescriptive Foundation Wall Support Systems .....                                      | 225- 42 |
| 6.3 Footings .....   | 225- 19 | 13.5 Prescriptive Wood Cripple Wall Support<br>Systems .....                                 | 225- 45 |
| 6.4 Permanent Foundations .....  | 225- 21 | <b>Chapter 14 Seismic Installation and Equipment<br/>Bracing Requirements</b> .....          | 225- 46 |
| 6.5 Special Considerations .....                                       | 225- 21 | 14.1 General .....   | 225- 46 |
| <b>Chapter 7 Installation Procedures</b> .....                         | 225- 23 | 14.2 Site-Installed Water Heaters .....  | 225- 46 |
| 7.1 Before Moving Manufactured Home to<br>Location .....               | 225- 23 | 14.3 Site-Installed Equipment .....  | 225- 46 |
| 7.2 Positioning of Home .....  | 225- 23 | 14.4 Utility Attachments .....   | 225- 47 |
| 7.3 Interconnection of Multisection Homes .....                        | 225- 23 | <b>Chapter 15 Prescriptive Flood Provision Designs</b> .....                                 | 225- 47 |
| 7.4 Crossover Connections for Multisection<br>Manufactured Homes ..... | 225- 23 | 15.1 Scope .....   | 225- 47 |
| 7.5 Anchoring Instructions .....                                       | 225- 24 | 15.2 Anchorage and Support Materials .....   | 225- 47 |
| 7.6 Installation of On-Site Structures .....                           | 225- 30 | 15.3 General Limitations .....   | 225- 47 |
| 7.7 Installation Close-Up/Finishing .....                              | 225- 30 | 15.4 Prescriptive Ground Anchor Support and<br>Anchorage System .....                        | 225- 47 |
| <b>Chapter 8 Site-Installed Features</b> .....                         | 225- 31 | 15.5 Prescriptive Foundation Wall Support and<br>Anchorage Systems .....                     | 225- 47 |
| 8.1 Installation of Site-Installed Features .....                      | 225- 31 |  |         |
| 8.2 Hinged Roofs and Eaves .....                                       | 225- 31 |  |         |
| 8.3 Garden and Bay Windows .....                                       | 225- 31 |  |         |
| 8.4 Awnings and Ramadas .....  | 225- 31 |  |         |
| 8.5 Miscellaneous Lights and Fixtures .....                            | 225- 31 |  |         |
| 8.6 Ventilation Options .....  | 225- 32 |  |         |
| 8.7 Optional Panels, Siding, and Molding .....                         | 225- 33 |  |         |
| 8.8 Skirting .....   | 225- 33 |  |         |

---

|                |   |                |                |                                       |               |
|----------------|---|----------------|----------------|---------------------------------------|---------------|
| <b>Annex A</b> | <b>Explanatory Material .....</b>   | <b>225- 55</b> | <b>Annex E</b> | <b>Informational References .....</b> | <b>225-64</b> |
| <b>Annex B</b> | <b>Final Inspection Checklist .....</b>                                     | <b>225-60</b>  | <b>Index</b>   | <b>.....</b>                          | <b>225-66</b> |
| <b>Annex C</b> | <b>Sample Checklist for AHJ Officials .....</b>                             | <b>225-60</b>  |                |                                       |               |
| <b>Annex D</b> | <b>Sample Schedule for Manufactured<br/>Home Installation Permits .....</b> | <b>225-64</b>  |                |                                       |               |

## NFPA 225

## Model Manufactured Home Installation Standard

2021 Edition

**IMPORTANT NOTE:** This NFPA document is made available for use subject to important notices and legal disclaimers. These notices and disclaimers appear in all publications containing this document and may be found under the heading “Important Notices and Disclaimers Concerning NFPA Standards.” They can also be viewed at [www.nfpa.org/disclaimers](http://www.nfpa.org/disclaimers) or obtained on request from NFPA.

**UPDATES, ALERTS, AND FUTURE EDITIONS:** New editions of NFPA codes, standards, recommended practices, and guides (i.e., NFPA Standards) are released on scheduled revision cycles. This edition may be superseded by a later one, or it may be amended outside of its scheduled revision cycle through the issuance of Tentative Interim Amendments (TIAs). An official NFPA Standard at any point in time consists of the current edition of the document, together with all TIAs and Errata in effect. To verify that this document is the current edition or to determine if it has been amended by TIAs or Errata, please consult the National Fire Codes® Subscription Service or the “List of NFPA Codes & Standards” at [www.nfpa.org/docinfo](http://www.nfpa.org/docinfo). In addition to TIAs and Errata, the document information pages also include the option to sign up for alerts for individual documents and to be involved in the development of the next edition.

**NOTICE:** An asterisk (\*) following the number or letter designating a paragraph indicates that explanatory material on the paragraph can be found in Annex A.

A reference in brackets [ ] following a section or paragraph indicates material that has been extracted from another NFPA document. Extracted text may be edited for consistency and style and may include the revision of internal paragraph references and other references as appropriate. Requests for interpretations or revisions of extracted text shall be sent to the technical committee responsible for the source document.

Information on referenced and extracted publications can be found in Chapter 2 and Annex E.

### Chapter 1 Administration

#### 1.1\* Scope.

**1.1.1** This model standard shall cover the installation of manufactured homes.

**1.1.2** The manufacturer’s installation instructions shall apply under either of the following conditions:

- (1) To items not covered by this standard
- (2) Where the manufacturer’s approved installation instructions provide a specific method of performing a specific operation or assembly

#### 1.2 Purpose. (Reserved)

**1.3 Application.** The provisions of this standard shall apply to manufactured homes used as dwelling units. This standard makes no provisions for other residential occupancies.

**1.3.1** This standard shall not apply to manufactured homes used for other than dwelling purposes.

**1.3.2** The provisions of this standard shall not apply to recreational vehicles as defined in NFPA 1192, or to park trailers as defined in ANSI/RVIA A119.5, *Recreational Park Trailers*.

**1.3.3\*** The provisions of this standard shall apply to park trailers labeled as manufactured homes.

**1.3.4** The manufactured homes covered by this standard shall comply with the U.S. Department of Housing and Urban Development (HUD) federal Manufactured Home Construction and Safety Standards (MHCSS) Program, as set forth in 24 CFR 3280, “Manufactured Home Construction and Safety Standards”; 24 CFR 3282, “Manufactured Home Procedural and Enforcement Regulations”; and 24 CFR 3285, “Model Manufactured Home Installation Standard.” Mobile homes built prior to June 15, 1976, are also covered by this standard.

**1.3.5** This standard is designed to be adopted by authorities having jurisdiction over, and responsibility for, the safety and health of manufactured home users. It is intended to apply to all home installations, whether at new or existing manufactured home sites.

**1.3.6 Flood Hazard Areas.** The provisions of this standard shall apply to installations on home sites that are wholly or partly located in flood hazard areas, including installations of new manufactured homes, replacement manufactured homes, substantial improvement of existing manufactured homes, and repair of substantially damaged manufactured homes. Installations in flood hazard areas shall meet the requirements of Chapter 12.

**1.3.6.1\* Pre-Installation Considerations.** Prior to the installation of a manufactured home, it shall be determined whether the home site lies wholly or partly within a special flood hazard area as shown on the authority having jurisdiction’s (AHJ’s) flood hazard map. If the AHJ has not adopted a flood hazard map, the AHJ shall be consulted to determine installation requirements.

**1.4 Retroactivity.** The provisions of this standard reflect a consensus of what is necessary to provide an acceptable degree of protection from the hazards addressed in this standard at the time the standard was issued.

**1.4.1** Unless otherwise specified, the provisions of this standard shall not apply to facilities, equipment, structures, or installations that existed or were approved for construction or installation prior to the effective date of the standard. Where specified, the provisions of this standard shall be retroactive.

**1.4.2** In those cases where the authority having jurisdiction determines that the existing situation presents an imminent danger, the authority having jurisdiction shall be permitted to apply retroactively any portions of this standard deemed appropriate.

**1.4.3** The retroactive requirements of this standard shall be permitted to be modified if their application clearly would be impractical in the judgment of the authority having jurisdiction, and only where it is clearly evident that a reasonable degree of safety is provided.

**1.5 Term Use.** The term *manufactured home* where used in this document shall be permitted to be used interchangeably with *home*.

## 1.6 Equivalency.

**1.6.1 General.** Nothing in this standard shall be intended to prevent use of systems, fire resistance, effectiveness, durability, and safety over those prescribed by this standard. Technical documentation shall be submitted to the authority having jurisdiction to demonstrate equivalency. The system, method, or device shall be approved for the intended purpose by the AHJ.

**1.6.2 Approval of Alternatives.** Alternative systems, methods, or devices approved as equivalent by the AHJ shall be recognized as being in compliance with this standard.

**1.6.3 Permitted Alternatives.** The provisions of this standard shall not be construed to prevent the use of construction systems, materials, or methods of design, or interpolations, calculations, evaluations, or similar evidence based on test data acceptable to the AHJ, as alternatives to the standards and provisions set forth in this standard. Such alternatives shall be permitted to be offered for approval, and their consideration shall be as provided in 1.6.2 through 1.6.5.

**1.6.4 Standards.** Construction systems, materials, or methods of design referred to in this standard shall be considered as standards of quality and strength. New or alternative construction systems, materials, or methods of design shall be at least equal to, and shall meet the intent of, these standards for the corresponding use intended.

**1.6.5 Systems, Materials, and Methods.** Any person desiring to use construction systems, materials, or methods of design not specifically mentioned in this standard shall file with the authority having jurisdiction a request for permission to use such systems, materials, or methods. Where alternative construction systems or materials are requested, the request shall be submitted with documentation, in writing, that supports claims of the sufficiency of such construction systems or materials. If a test installation is proposed, a description of the location and purpose of the test shall also be submitted.

**1.6.6 Approval.** The AHJ shall approve alternate construction systems, materials, or methods of design when it is substantiated that the requirements of this standard are at least equaled. If, in the opinion of the AHJ, the requirements of this standard are not equaled by the alternative requested, approval for permanent work shall be refused. Consideration shall be given to test or prototype installations.

### 1.6.7 Tests.

**1.6.7.1** Whenever there is insufficient evidence of compliance with the requirements of this standard, evidence that any material or method of construction does not conform to the requirements of this standard or insufficient evidence to substantiate claims for alternative construction systems, materials, or methods of construction, the AHJ shall be permitted to require tests for proof of compliance to be made by an approved agency at the expense of the owner or owner's agent.

**1.6.7.2** Test methods shall be as specified by this standard for the material in question. If there are not appropriate test methods specified in the standard, the AHJ is authorized to accept an applicable test procedure from another source.

**1.6.7.3** Copies of the results of all tests shall be retained for not less than 2 years after the acceptance of the building or structure.

**1.6.8 Appeal.** Any person whose request for use of alternative systems and materials or methods of design has been refused by the authority having jurisdiction shall be permitted to appeal to the board of appeals.

## Chapter 2 Referenced Publications

**2.1 General.** The documents or portions thereof listed in this chapter are referenced within this standard and shall be considered part of the requirements of this document.

**2.2 NFPA Publications.** National Fire Protection Association, 1 Batterymarch Park, Quincy, MA 02169-7471.

NFPA 13D, *Standard for the Installation of Sprinkler Systems in One- and Two-Family Dwellings and Manufactured Homes*, 2019 edition.

NFPA 70®, *National Electrical Code®*, 2020 edition.

NFPA 72®, *National Fire Alarm and Signaling Code®*, 2019 edition.

NFPA 286, *Standard Methods of Fire Tests for Evaluating Contribution of Wall and Ceiling Interior Finish to Room Fire Growth*, 2019 edition.

NFPA 501, *Standard on Manufactured Housing*, 2021 edition.

NFPA 501A, *Standard for Fire Safety Criteria for Manufactured Home Installations, Sites, and Communities*, 2021 edition.

NFPA 1192, *Standard on Recreational Vehicles*, 2021 edition.

NFPA 5000®, *Building Construction and Safety Code®*, 2021 edition.

### 2.3 Other Publications.

**2.3.1 AF&PA Publications.** American Forest & Paper Association, 1101 K Street, NW, Suite 700, Washington, DC 20005-4210.

ANSI/AF&PA *Wood Frame Construction Manual (WFCM)*, 2001.

**2.3.2 ASCE Publications.** American Society of Civil Engineers, 1801 Alexander Bell Drive, Reston, VA 20191.

ASCE/SEI 7, *Minimum Design Loads for Buildings and Other Structures*, 2005.

ASCE/SEI 24, *Flood Resistant Design and Construction*, 2014.

**2.3.3 ASTM Publications.** ASTM International, 100 Barr Harbor Drive, West Conshohocken, PA 19428-2959.

ASTM C90, *Standard Specification for Loadbearing Concrete Masonry Units*, 2016a.

ASTM D3953, *Standard Specification for Strapping, Flat Steel and Seals*, 2015.

ASTM D4318, *Standard Test Methods for Liquid Limit, Plastic Limit, and Plasticity Index of Soils* 2017e1.

ASTM E84, *Standard Test Method for Surface Burning Characteristics of Building Materials*, 2020.

**2.3.4 RVIA Publications.** Recreation Vehicle Industry Association, 1896 Preston White Drive, Reston, VA 20191.

ANSI/RVIA A119.5, *Recreational Park Trailers*, 2015.



**2.3.5 UL Publications.** Underwriters Laboratories Inc., 333 Pfingsten Road, Northbrook, IL 60062-2096.

UL 723, *Test for Surface Burning Characteristics of Building Materials*, 2018.

**2.3.6 U.S. Government Publications.** U.S. Government Publishing Office, 732 North Capitol Street, NW, Washington, DC 20401-0001.

Title 24, Code of Federal Regulations, Part 3280, "Manufactured Home Construction and Safety Standards."

Title 24, Code of Federal Regulations, Part 3282, "Manufactured Home Procedural and Enforcement Regulations."

Title 24, Code of Federal Regulations, Part 3285, "Model Manufactured Home Installation Standard."

**2.3.7 USGS Publications.** United States Geological Survey National Center, 12201 Sunrise Valley Drive, Reston, VA 20192.

*Seismic Design Category Map*, 2000.

**2.3.8 Other Publications.**

*Merriam-Webster's Collegiate Dictionary*, 11th edition, Merriam-Webster, Inc., Springfield, MA, 2003.

**2.4 References for Extracts in Mandatory Sections.**

NFPA 101<sup>®</sup>, *Life Safety Code*<sup>®</sup>, 2021 edition.

NFPA 501A, *Standard for Fire Safety Criteria for Manufactured Home Installations, Sites, and Communities*, 2021 edition.

NFPA 5000<sup>®</sup>, *Building Construction and Safety Code*<sup>®</sup>, 2021 edition.

## Chapter 3 Definitions

**3.1 General.** The definitions contained in this chapter shall apply to the terms used in this standard. Where terms are not defined in this chapter or within another chapter, they shall be defined using their ordinarily accepted meanings within the context in which they are used. *Merriam-Webster's Collegiate Dictionary*, 11th edition, shall be the source for the ordinarily accepted meaning.

**3.2 NFPA Official Definitions.**

**3.2.1\* Approved.** Acceptable to the authority having jurisdiction.

**3.2.2\* Authority Having Jurisdiction (AHJ).** An organization, office, or individual responsible for enforcing the requirements of a code or standard, or for approving equipment, materials, an installation, or a procedure.

**3.2.3 Labeled.** Equipment or materials to which has been attached a label, symbol, or other identifying mark of an organization that is acceptable to the authority having jurisdiction and concerned with product evaluation, that maintains periodic inspection of production of labeled equipment or materials, and by whose labeling the manufacturer indicates compliance with appropriate standards or performance in a specified manner.

**3.2.4\* Listed.** Equipment, materials, or services included in a list published by an organization that is acceptable to the authority having jurisdiction and concerned with evaluation of products or services, that maintains periodic inspection of

production of listed equipment or materials or periodic evaluation of services, and whose listing states that either the equipment, material, or service meets appropriate designated standards or has been tested and found suitable for a specified purpose.

**3.2.5 Shall.** Indicates a mandatory requirement.

**3.2.6 Should.** Indicates a recommendation or that which is advised but not required.

**3.2.7 Standard.** An NFPA Standard, the main text of which contains only mandatory provisions using the word "shall" to indicate requirements and that is in a form generally suitable for mandatory reference by another standard or code or for adoption into law. Nonmandatory provisions are not to be considered a part of the requirements of a standard and shall be located in an appendix, annex, footnote, informational note, or other means as permitted in the NFPA Manuals of Style. When used in a generic sense, such as in the phrase "standards development process" or "standards development activities," the term "standards" includes all NFPA Standards, including Codes, Standards, Recommended Practices, and Guides.

**3.3 General Definitions.**

**3.3.1 Alteration.** See 3.3.17, Installation Alteration.

**3.3.2 Anchor.** A device placed at the manufactured home site designed to transfer home anchoring loads to the ground.

**3.3.3 Anchoring Equipment.** Ties, straps, cables, turnbuckles, chains, and other approved components, including tensioning devices, that are used to secure a manufactured home to anchors.

**3.3.4 Anchoring System.** A combination of anchoring equipment and anchors that will, when properly designed and installed, resist the uplift, overturning, and lateral forces on the manufactured home.

**3.3.5 Arid.** An area subject to 15 in. (381 mm) or less of annual rainfall.

**3.3.6\* Crossovers.** Utility connections in multisection homes that are located where the sections are joined.

**3.3.7 Dwelling Unit.** One or more rooms arranged for complete, independent housekeeping purposes with space for eating, living, and sleeping; facilities for cooking; and provisions for sanitation. [101, 2021]

**3.3.8 Elevation.**

**3.3.8.1 Base Flood Elevation (BFE).** The elevation of the base flood, including wave height, relative to the datum specified on a jurisdiction's flood hazard map. [5000, 2021]

**3.3.8.2 Design Flood Elevation (DFE).** The elevation of the design flood, including wave height, relative to the datum specified on a jurisdiction's flood hazard map. [5000, 2021]

**3.3.9 Flood.**

**3.3.9.1 Base Flood.** The flood having a 1 percent chance of being equaled or exceeded in any given year. [5000, 2021]

**3.3.9.2 Design Flood.** The greater of either (1) the base flood or (2) the flood so designated by the jurisdiction as its regulatory flood, with a 1 percent chance, or less, of being equaled or exceeded in any given year. [5000, 2021]

**3.3.10 Flood Damage-Resistant Material.** Any construction material capable of direct and prolonged contact with floodwaters without sustaining any damage that requires more than cosmetic repairs. [5000, 2021]

**3.3.11\* Flood Hazard Area.** The greater of either (1) the special flood hazard area shown on the flood insurance rate map or (2) the area subject to flooding during the design flood and shown on a jurisdiction's flood hazard map, or otherwise legally designated. [5000, 2021]

**3.3.12 Flood Hazard Map.** A map delineating the flood hazard area and adopted by a jurisdiction. [5000, 2021]

**3.3.13 Footing.** That portion of the support system that transmits loads directly to the soil.

**3.3.14\* Foundation Wall.** A wall below the floor nearest grade that serves as a structural support for the home.

**3.3.15 Imminent Danger.** A condition or practice in an occupancy, structure, site, or community that poses a danger that could reasonably be expected to cause death, serious physical harm, or serious property loss.

**3.3.16 Installation.** Assembly, at the site of occupancy, of all portions of the manufactured home, connection of the home to existing utility connections, and installation of support and anchoring systems.

**3.3.17 Installation Alteration.** The replacement, addition, modification, or removal of any components of the required ground support or anchoring systems.

**3.3.18 Installation Instructions.** Instructions provided by the manufacturer that accompany each manufactured home and detail the manufacturer's requirements for ground support, anchoring systems, and other work completed on site.

**3.3.19\* Lowest Floor.** The floor of the lowest enclosed area of a manufactured home. For the purpose of this standard, *lowest floor* shall mean the bottom of the longitudinal chassis frame beam in A zones, and the bottom of the lowest horizontal structural member supporting the home in V zones. An unfinished or flood-resistant enclosure, used solely for vehicle parking, home access or limited storage, shall not be considered the lowest floor, provided the enclosed area is not constructed so as to render the home in violation of the flood-related provisions of this standard.

**3.3.20 Manufactured Home.** A structure, transportable in one or more sections, which, in the traveling mode, is 8 body-ft (2.4 m) or more in width or 40 body-ft (12.2 m) or more in length or, when erected on site, is 320 ft<sup>2</sup> (29.7 m<sup>2</sup>) or more and that is built on a permanent chassis and designed to be used as a dwelling, with or without a permanent foundation, when connected therein except that such terms shall include any structure that meets all the requirements of this paragraph except the size requirements and with respect to which the manufacturer voluntarily files a certification required by the regulatory agency. Calculations used to determine the number of square feet in a structure are based on the structure's exterior dimensions, measured at the largest horizontal projections when erected on site. These dimensions include all expandable

rooms, cabinets, and other projections containing interior space, but do not include bay windows.

**3.3.20.1 New Manufactured Home.** A manufactured home that has not been sold to a person/consumer for purposes other than retail sale.

**3.3.21\* Manufactured Home Accessory Building or Structure.** A building or structure that is an addition to or supplements the facilities provided by a manufactured home.

**3.3.22 Manufactured Home Gas Supply Connector.** A listed connector designed for connecting the manufactured home to the gas supply source. [501A, 2021]

**3.3.23 Manufactured Home Park or Subdivision.** For all matters related to installation in flood hazard areas, the term *manufactured home park or subdivision* shall mean a parcel (or contiguous parcels) of land divided into two or more manufactured home sites for sale or rent.

**3.3.23.1 Existing Manufactured Home Park or Subdivision.** For all matters related to installation in flood hazard areas, the term *existing manufactured home park or subdivision* shall mean a home park or subdivision for which the construction of facilities for servicing the sites (including, at a minimum, the installation of utilities, the construction of streets, and either final site grading or installation of pads) was completed prior to the effective date of the initial adoption of floodplain management regulations or map by the AHJ.

**3.3.23.2 New Manufactured Home Park or Subdivision.** For all matters related to installation in flood hazard areas, the term *new manufactured home park or subdivision* shall mean a home park or subdivision for which the construction of facilities for servicing the sites (including, at a minimum, the installation of utilities, the construction of streets, and either final site grading or installation of pads) is completed on or after the effective date of the initial adoption of floodplain management regulations or map by the AHJ.

**3.3.24 Manufactured Home Site.** A parcel of land for the accommodation of one manufactured home, its accessory buildings or structures, and accessory equipment for the exclusive use of the occupants. [501A, 2021]

**3.3.25\* Pier.** An isolated support used in a support system extending between the footing and the manufactured home.

**3.3.26 Ramada.** Any freestanding roof or shade structure installed or erected above a manufactured home or any portion thereof. [501A, 2021]

**3.3.27 Skirting.** A weather-resistant material used to enclose the perimeter of the conditioned living area of the home from the bottom of the manufactured home to grade.

**3.3.28 Stabilizing Devices.** All components of the anchoring and support systems, such as piers, footings, ties, anchoring equipment, anchors, or any other materials and methods of construction, that support and secure the manufactured home to the ground.

**3.3.29 Structure.** That which is built or constructed, an edifice or building of any kind, or any piece of work artificially built up or composed of parts joined together in some definite manner.

**3.3.30 Substantial Damage.** For manufactured homes, including support and anchoring systems, located wholly or partly

within the flood hazard areas, damage of any origin whereby the cost of restoring the manufactured home, including support and anchoring systems, to its predamage condition would equal or exceed 50 percent of the market value of the manufactured homes, including support and anchoring systems.

**3.3.31 Substantial Improvement.** For manufactured homes, including support and anchoring systems located wholly or partly within the flood hazard area: (1) any repair, addition, reconstruction, rehabilitation or improvement of the manufactured home, including support and anchoring systems, the cost of which equals or exceeds 50 percent of the market value of the manufactured homes, including support and anchoring systems; (2) if a manufactured home, including support and anchoring systems, has sustained substantial damage, any repairs or reconstruction regardless of the actual work performed. Substantial improvement shall not include any project or improvement of a manufactured home required to correct existing health, sanitary, or safety code violations identified by the AHJ, and that are the minimum necessary to assure safe living conditions.

**3.3.32 Support System.** Piers, foundation walls, and other equivalent systems approved in accordance with 4.5.1.3 and their footings, anchorage to the manufactured home, shims, and any combination thereof that, when properly installed, support the manufactured home.

**3.3.33 Tie.** See 3.3.3, Anchoring Equipment.

**3.3.33.1 Diagonal Tie.** A tie intended to resist horizontal or shear forces and to resist vertical, uplift, and overturning forces.

**3.3.33.2 Vertical Tie.** A tie intended to resist uplifting and overturning forces.

**3.3.34 Utility Connection.** The connection of the manufactured home to existing utilities that include, but are not limited to, electricity, water, sewer, gas, or fuel oil.

## Chapter 4 General

### 4.1 Preinstallation Considerations.

**4.1.1** Prior to location or relocation of a manufactured home, the authority having jurisdiction shall be contacted for installation and permitting requirements.

**4.1.2 Flood Hazard Areas.** See Chapter 12.

**4.2\* Alterations.** Prior to alteration of a home installation, the authority having jurisdiction shall be contacted to determine if plan approval and permit are required.

**4.3\* Data Plate.** The home installation shall be capable of resisting the loads and conditions listed on the data plate.

**4.4 Installation Considerations.** The items listed in 4.4.1 through 4.4.4 shall be reviewed prior to installing the manufactured home.

**4.4.1 Installation Instructions.** Specific installation methods, operations, and assemblies in the manufacturer's installation instructions (if available) shall be followed.

**4.4.2 Utility Schematics.** Field installations shall be in accordance with the utility schematics provided by the manufacturer, or as required by the AHJ.

**4.4.3 Home Installation Manual Supplements.** Supplemental pages shall be permitted to be included with the home, outlining special features in the home that are not covered or that differ from this document.

**4.4.4** The home shall be installed in accordance with the design zone maps indicated on the data plate.

**4.5 Design and Construction.** Installation of manufactured homes, including support and anchoring systems, shall be designed and constructed to support all loads and load combinations required by this chapter and elsewhere in this standard.

**4.5.1 Design Methods.** Design of support systems and their connection to the manufactured home shall be in accordance with 4.5.1.1, 4.5.1.2, or 4.5.1.3.

**4.5.1.1 Prescriptive Design.** Design shall be in accordance with the provisions of this standard.

**4.5.1.2 Engineered Design.** Design shall be in accordance with ASCE/SEI 7, *Minimum Design Loads for Buildings and Other Structures*.

**4.5.1.3 Equivalency.** Equivalent systems shall be permitted if approved by the authority having jurisdiction.

**4.5.2 Combined Design Methods.** Support systems shall not be designed using a combination of prescriptive design in accordance with 6.2.3 through 6.2.5 and engineered design in accordance with 4.5.1.2 or equivalency in accordance with 4.5.1.3, within the support system for a single home or accessory building.

### 4.5.3 Seismic Design.

#### 4.5.3.1 Seismic Design Criteria.

**4.5.3.1.1 Determination of Seismic Design Category.** Seismic design categories (SDC) shall be determined from either Table 4.5.3.1.1 or Figure 4.5.3.1.1.

**4.5.3.1.2 SDC A, B, and C.** The provisions of 4.5.3.2 through 4.5.3.4 shall not apply to SDC A, SDC B, or SDC C.

**4.5.3.1.3 SDC D<sub>0</sub>, D<sub>1</sub>, D<sub>2</sub>, and E.** Manufactured homes located in SDC D<sub>0</sub>, D<sub>1</sub>, D<sub>2</sub>, and E shall meet the additional requirements of either 4.5.3.2 or 4.5.3.3, and 4.5.3.4.

#### 4.5.3.2 Prescriptive Design.

**4.5.3.2.1** Prescriptive design in accordance with the seismic requirements of Chapter 13 shall be permitted for homes located in seismic design categories D<sub>0</sub>, D<sub>1</sub>, D<sub>2</sub>, or E, provided the following:

- (1) The 3-second gust basic wind speed is 90 mph (40.2 m/sec) or less, and
- (2) The home is located outside of a flood hazard area, or
- (3) If within a flood hazard area, is located outside a V zone or floodway

**4.5.3.2.2** All other homes located in seismic design categories D<sub>0</sub>, D<sub>1</sub>, D<sub>2</sub>, or E shall have an engineered design or approved equivalent system.

Table 4.5.3.1.1 Seismic Design Category by County

| Seismic Design Category | State  | Counties  |
|-------------------------|--|---|
| SDCD <sub>1</sub>       | Alaska   | Bristol Bay, Juneau, Northwest Arctic   |
|                         | Arizona  | Coconino, La Paz, Mohave, Pima  |
|                         | Arkansas   | Arkansas, Cleburne, Faulkner, Fulton, Izard, Lonoke, Monroe, Montgomery, Phillips, Prairie, Pulaski, Sharp, Stone, Van Buren, White   |
|                         | California   | Butte, Calaveras, Madera, Sutter, Yuba  |
|                         | Georgia  | Catoosa, Murray, Whitfield  |
|                         | Hawaii   | Honolulu  |
|                         | Idaho  | Adams, Bannock, Bingham, Blaine, Camas, Cassia, Elmore, Franklin, Gem, Jefferson, Madison, Power, Valley, Washington  |
|                         | Illinois   | Bond, Clay, Clinton, Crawford, Edwards, Effingham, Fayette, Jasper, Jefferson, Lawrence, Madison, Marion, Monroe, Randolph, Richland, St. Clair, Wabash, Washington, Wayne  |
|                         | Indiana  | Gibson, Knox, Pike, Posey, Spencer, Vanderburgh, Warrick  |
|                         | Kentucky   | Christian, Daviess, Henderson, Hopkins, McLean, Muhlenberg, Webster   |
|                         | Maine  | Aroostook   |
|                         | Mississippi  | Benton, Coahoma, Lafayette, Marshall, Panola, Quitman, Tate   |
|                         | Missouri   | Carter, Iron, Jefferson, Madison, Oregon, Reynolds, St. Francois, St. Louis, Ste. Genevieve, Shannon, Washington  |
|                         | Montana  | Glacier, Granite, Lewis and Clark, Lincoln, Meagher, Powell, Silver Bow   |
|                         | Nevada   | Clark, Pershing, White Pine   |
|                         | New Mexico   | Bernalillo, Los Alamos, Rio Arriba, Sandoval, Santa Fe, Socorro, Valencia   |
|                         | New York   | Clinton, Essex, Franklin, St. Lawrence  |
|                         | North Carolina   | Cherokee, Columbus, Graham, Swain   |
|                         | Oregon   | Baker, Harney, Hood River, Jackson, Linn, Malheur, Umatilla   |
|                         | South Carolina   | Aiken, Allendale, Barnwell, Beaufort, Chesterfield, Darlington, Dillon, Fairfield, Hampton, Jasper, Kershaw, Lee, Lexington, Madsboro, Richland   |
| Tennessee               | Benton, Blount, Bradley, Chester, Cocke, Decatur, Grainger, Hamblen, Hamilton, Hardeman, Hardin, Henderson, Houston, Humphreys, Jefferson, Knox, Loudon, McMinn, McNairy, Monroe, Montgomery, Polk, Sevier, Stewart, Union |   |
| Texas                   | El Paso, Hudspeth  |   |
| Utah                    | Beaver, Carbon, Emery, Garfield, Kane, Millard, Piute, Sanpete, Sevier, Washington, Wayne  |   |
| Vermont                 | Franklin, Grand Isle   |   |
| Washington              | Benton, Chelan, Kittitas, Klickitat, Skamania, Walla Walla, Yakima   |   |
| SDCD <sub>2</sub>       | Alaska   | Fairbanks North Star, Sitka   |
|                         | Arizona  | Yuma  |
|                         | Arkansas   | Independence, Lee, Randolph, Woodruff   |
|                         | California   | Amador, Glenn, Mariposa, Tulare, Tuolumne   |
|                         | Hawaii   | Mau   |
|                         | Idaho  | Boise, Bonneville, Butte, Caribou, Clark, Lemhi, Oneida, Teton  |
|                         | Illinois   | Franklin, Callatin, Hamilton, Hardin, Perry, Saline, White  |
|                         | Kentucky   | Caldwell, Calloway, Crittenden, Lyon, Trigg, Union  |
|                         | Mississippi  | DeSoto, Tunica  |
|                         | Missouri   | Perry, Ripley, Wayne  |
|                         | Montana  | Broadwater, Flutehead, Jefferson, Missoula, Park, Sanders   |
|                         | Nevada   | Churchill, Elko, Eureka, Humboldt, Lander, Lincoln, Nye   |
|                         | Oregon   | Clackamas, Columbia, Lake, Marion, Multnomah, Washington  |
|                         | South Carolina   | Bamberg, Calhoun, Horry, Marion, Sumter   |
|                         | Tennessee  | Bedford, Carroll, Fayette, Henry, Madison   |
|                         | Utah   | Iron, Juab, Morgan, Rich, Tooele, Wasatch   |
|                         | Washington   | Clark, Cowlitz, Lewis, San Juan, Skagit, Thurston, Whatcom  |
| Wyoming                 | Park, Sublette   |   |
| SDCD <sub>2</sub>       | Alaska   | Aleutians East, Anchorage, Denali, Haines, Lake and Peninsula, Matanuska-Susitna  |
|                         | Arkansas   | Jackson, Lawrence   |
|                         | California   | Colusa, Del Norte, El Dorado, Fresno, Kings, Merced, Modoc, Nevada, Placer, Plumas, Sacramento, San Joaquin, Sierra, Siskiyou, Stanislaus, Tehama, Yolo   |
|                         | Idaho  | Bear Lake, Custer, Fremont  |
|                         | Illinois   | Jackson, Pope, Willamson  |
|                         | Kentucky   | Livingston, Marshall  |
|                         | Missouri   | Bollinger, Butler   |
|                         | Montana  | Beaverhead, Callatin, Lake, Madison   |
|                         | Nevada   | Lyon, Mineral, Storey, Washoe   |
|                         | Oregon   | Benton, Clatsop, Coos, Curry, Douglas, Josephine, Klamath, Lane, Lincoln, Polk, Tillamook, Yamhill  |
|                         | South Carolina   | Berkeley, Charleston, Clarendon, Colleton, Dorchester, Florence, Georgetown, Orangeburg, Williamsburg   |
|                         | Tennessee  | Weakley   |
|                         | Utah   | Box Elder, Cache, Summit, Utah  |
|                         | Washington   | Clallam, Guay Harbor, Island, Jefferson, King, Kitsap, Mason, Pacific, Pierce, Snohomish, Wahkaikum   |
| Wyoming                 | Lincoln, Teton   |   |
| SDCE                    | Alaska   | Kenai Peninsula, Kodiak Island, Yakutat   |
|                         | Arkansas   | Clay, Craighead, Crittenden, Cross, Greene, Mississippi, Poinsett, St. Francis  |
|                         | California   | Alameda, Alpine, Contra Costa, Humboldt, Imperial, Inyo, Kern, Lake, Lassen, Los Angeles, Marin, Mendocino, Mono, Monterey, Napa, Orange, Riverside, San Benito, San Bernardino, San Diego, San Francisco, San Luis Obispo, San Mateo, Santa Barbara, Santa Clara, Santa Cruz, Shasta, Solano, Sonoma, Trinity, Ventura |
|                         | Hawaii   | Hawaii  |
|                         | Illinois   | Alexander, Johnson, Massac, Pulaski, Union  |
|                         | Kentucky   | Ballard, Cadishe, Fulton, Craves, Hickman, McClacken  |
|                         | Missouri   | Cape Girardeau, Dunklin, Mississippi, New Madrid, Pemiscot, Scott, Stoddard   |
|                         | Nevada   | Douglas, Esmeralda  |
|                         | Tennessee  | Crockett, Dyer, Gibson, Haywood, Lake, Lauderdale, Obion, Shelby, Tipton  |
|                         | Utah   | Davis, Salt Lake, Weber   |

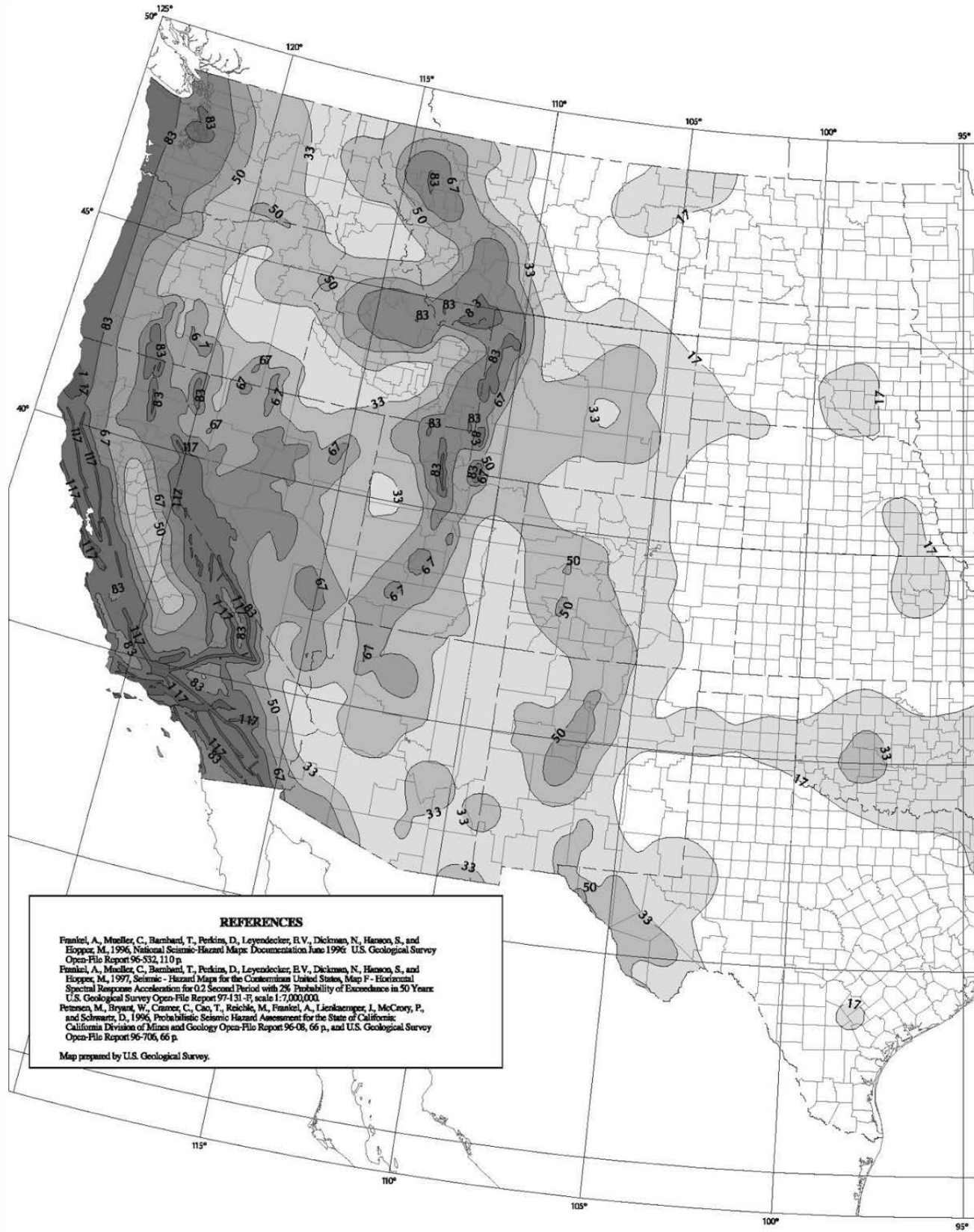

FIGURE 4.5.3.1.1 Seismic Design Category Map. (Source: U.S. Geological Survey)

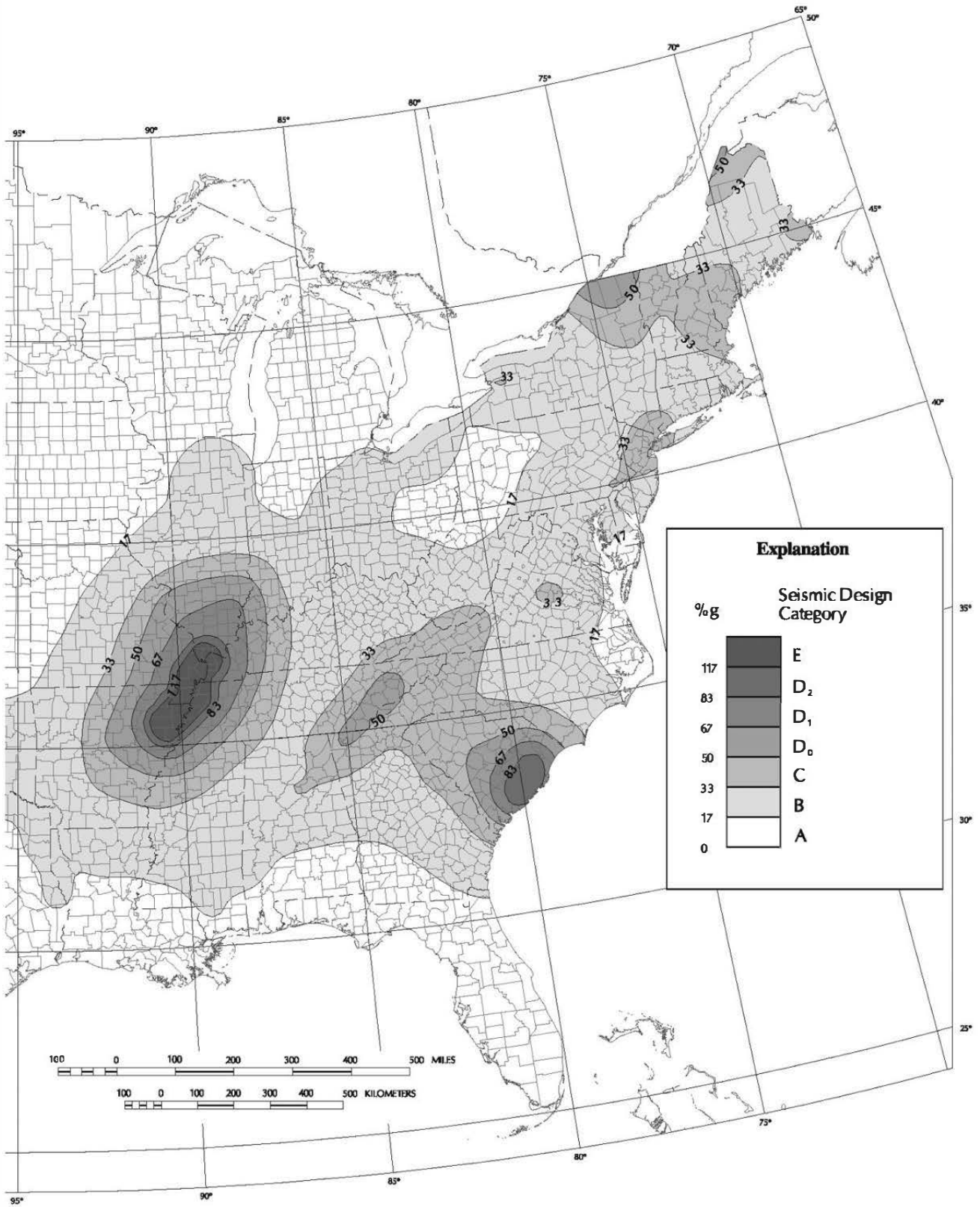

FIGURE 4.5.3.1.1 *Continued*

**4.5.3.3 Engineered Design.** Engineered design of support systems and their foundations and anchorage, in accordance with 4.5.1.2, shall include all applicable design loads and other applicable seismic provisions of ASCE/SEI 7, *Minimum Design Loads for Buildings and Other Structures*.

**4.5.3.4 Seismic Installation and Equipment Bracing Requirements.** Manufactured homes shall conform to the additional installation and equipment bracing requirements of Chapter 14.

## Chapter 5 Site Preparation

**5.1 Access for Transporter.** Before attempting to move a home, it shall be ensured that the transportation equipment and home can be routed to the installation site and that all transportation permits required by the state, county, or municipality have been obtained.

**5.2 Encroachments and Setback Distances.** Local laws regarding encroachments in streets, yards, and courts shall be obeyed, and permissible setback distances from property lines and public roads shall be met.

**5.3 Fire Separation Distance.** Fire separation distances shall be in accordance with Chapter 6 of NFPA 501A or the requirements of the authority having jurisdiction, whichever is more stringent.

**5.4 Issuance of Permits.** All necessary local permits shall be obtained, and all fees shall be paid.

### 5.5 Site Preparation.

**5.5.1** Prior to construction, the area to be occupied by the structure shall be cleared of debris, vegetation, and topsoil to a depth sufficient to remove all organic material.

**5.5.2** Soil that supports footings and foundations shall be capable of accommodating all loads required by this standard. Fill soil that supports footings and foundations shall be designed, installed, and tested in accordance with accepted engineering practice. The design bearing capacity of soil shall be determined in accordance with Section 5.6.

### 5.6 Investigation and Bearing Capacity of Soil.

**5.6.1\* Presumptive Capacities.** Where no unusual soil or saturation conditions are present, the allowable soil bearing pressures in Table 5.6.1 shall be permitted to be used. Higher values shall not be used unless they are substantiated by recognized tests, analysis, or other data, and then approved by the AHJ.

**5.6.2 Soil Investigation.** Where the soil-bearing capacity is unknown or questionable, the AHJ shall be permitted to require evaluation of subsoil conditions by a registered professional engineer or by a load test in accordance with NFPA 5000, 36.3.2. When approved by the AHJ, the soil-bearing capacity shall be permitted to be determined from local soil records.

### 5.6.3 Expansive Soils. [5000:36.3.3]

**5.6.3.1** Where the nature of the soil is not known in sufficient detail, the authority having jurisdiction shall be permitted to require testing to determine the expansive characteristics of the soil. [5000:36.3.3.1]

**Table 5.6.1 Maximum Allowable Soil Pressures**

| Class of Material                             | Minimum Depth of Footing Below Adjacent Ground |     | Pressure Permitted If Footing Is at Minimum Depth* |                   |
|---|--|-----|--|-------------------|
|   | ft   | m   | psf  | kN/m <sup>2</sup> |
| Compact fine sand                             | 1  | 0.3 | 1000†  | 48†               |
| Loose sand                                    | 2  | 0.6 | 500†   | 24†               |
| Medium stiff clay                             | 1  | 0.3 | 2000   | 96                |
| Soft, sandy clay or clay                      | 2  | 0.6 | 1000   | 48                |
| Compact inorganic sand and silt mixtures      | 1  | 0.3 | 1000   | 48                |
| Loose inorganic sand and silt mixtures        | 2  | 0.6 | 500  | 24                |
| Loose organic sand and silt mixtures and peat | —  | —   | 0  | 0                 |

\*These pressures are considered sufficient to prevent failure of the supporting ground but not to prevent excessive foundation movement or settlement where unusual soil or moisture conditions are encountered.

†Values are for footings 1 ft (0.30 m) wide and are permitted to be increased in direct proportion to the width of the footing to a maximum of 2½ times the designated value.

**5.6.3.2** Each potentially expansive stratum of soil above the level where a constant moisture content exists shall be tested in accordance with ASTM D4318, *Standard Test Methods for Liquid Limit, Plastic Limit, and Plasticity Index of Soils*, to determine its plasticity index (PI). [5000:36.3.3.2]

**5.6.3.2.1** Where the PI of all strata is less than 15, the soil shall not be considered expansive. [5000:36.3.3.2.1]

**5.6.3.2.2** Where the PI of any stratum is 15 or greater, the soil shall be considered potentially expansive and shall be subjected to additional approved tests and evaluation to determine if the soil will adversely affect the structural integrity and serviceability of the structure. [5000:36.3.3.2.2]

### 5.7 Drainage.

**5.7.1 Purpose.** Drainage shall be provided that prevents water buildup under the home, shifting or settling of the foundation, dampness in the home, damage to siding and bottom board, buckling of walls and floors, and problems with the operation of doors and windows.

**5.7.1.1** The home site shall be graded to permit water to drain from under the home. (See Figure 5.7.1.1.)

**5.7.1.2** All drainage shall be diverted away from the home.

**5.7.2\* Sloped Site Considerations.** Sloped sites shall be protected from surface runoff from the surrounding area.

**5.7.3 Drainage Structures.** Ditches and culverts shall be permitted to be used to drain surface runoff and to be included in the overall site preparation.

**5.7.4 Gutters and Downspouts.** When gutters and downspouts are installed, the runoff shall be directed away from the home.

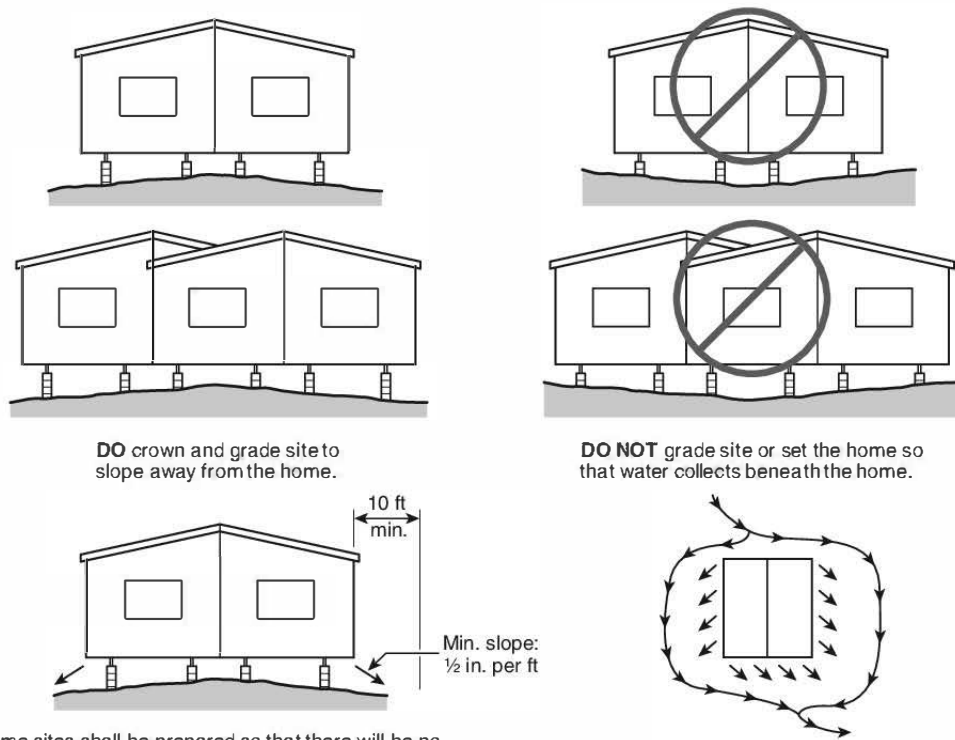

Home sites shall be prepared so that there will be no depressions in which surface water shall accumulate beneath the home. The area of the site covered by the manufactured home shall be graded, sloped, or mechanically designed so as to provide drainage from beneath the home or to property line.

Note: For SI units, 1 ft = 0.3048 m, 1 in. = 25.4 mm.

FIGURE 5.7.1.1 Grading and Drainage.

**5.8 Ground Moisture Control.**

**5.8.1 Vapor Retarder.** If the space under the home is to be enclosed with skirting or other material, a vapor retarder that keeps ground moisture out of the home shall be installed except in arid regions with dry soil conditions, or when approved by the AHJ.

**5.8.2 Acceptable Types of Ground Cover.** A minimum of 6-mil polyethylene sheeting or its equivalent shall be used.

**5.8.3 Proper Installation.**

**5.8.3.1** When the entire area under the home is required to be covered with the sheeting as noted in 5.8.1, it shall be overlapped at least 12 in. (305 mm) at all joints.

**5.8.3.2** Where soil and frost conditions permit placement of footings at grade level, the sheeting shall be placed directly beneath the footings.

**Chapter 6 Foundations**

**6.1 General.**

**6.1.1** Foundations for manufactured home installations shall be constructed in accordance with Chapter 6. Alternately, support systems shall be permitted to conform to engineered design methods in accordance with 4.5.1.2 or equivalency provisions in accordance with 4.5.1.3.

**6.1.2** Details, plans, and/or test data shall be submitted to the AHJ for approval.

**6.1.3 Flood Hazard Areas.** See Chapter 12.

**6.1.4 Seismic Design Categories D<sub>0</sub>, D<sub>1</sub>, D<sub>2</sub>, and E.** Support systems for manufactured homes in seismic design categories D<sub>0</sub>, D<sub>1</sub>, D<sub>2</sub>, and E shall meet the additional requirements of 4.5.3.

**6.2 Piers.**

**6.2.1\* General.** The piers used shall be capable of transmitting the vertical live and dead loads to the foundation below.

**6.2.2 Acceptable Piers — Materials Specification.**

**6.2.2.1\*** Piers shall be permitted to be concrete blocks, pressure-treated wood having 0.60 pcf (94 N/m<sup>3</sup>) retention, or adjustable metal or concrete piers as shown in Figure 6.2.2.1(a) and Figure 6.2.2.1(b).

**6.2.2.2** Manufactured piers shall be listed or labeled for the required load capacity.



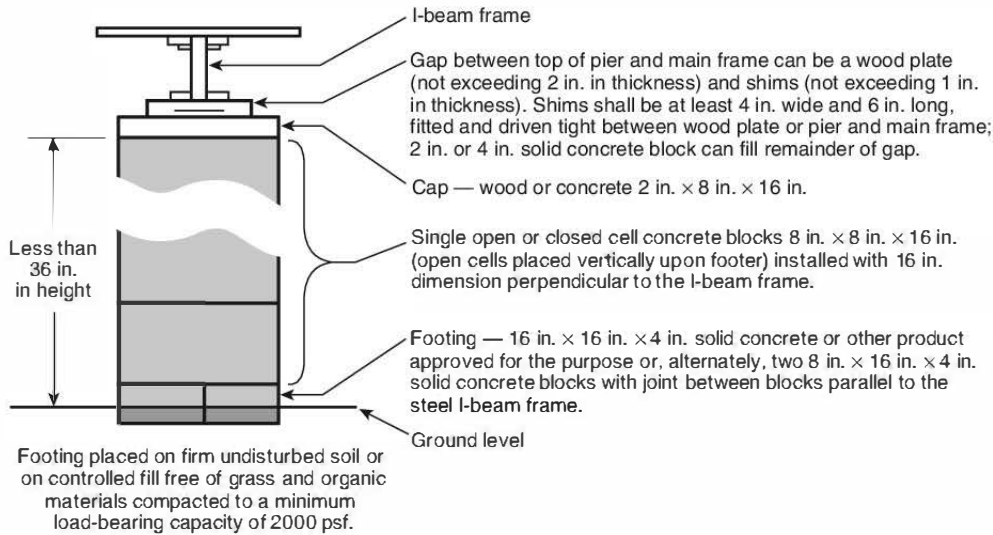

Note: For SI units, 1 in. = 25.4 mm, 1 psf = 0.04788 kN/m<sup>2</sup>.

**FIGURE 6.2.2.1(a) Typical Footing and Pier Installation — Less than 36 in. in Height.**

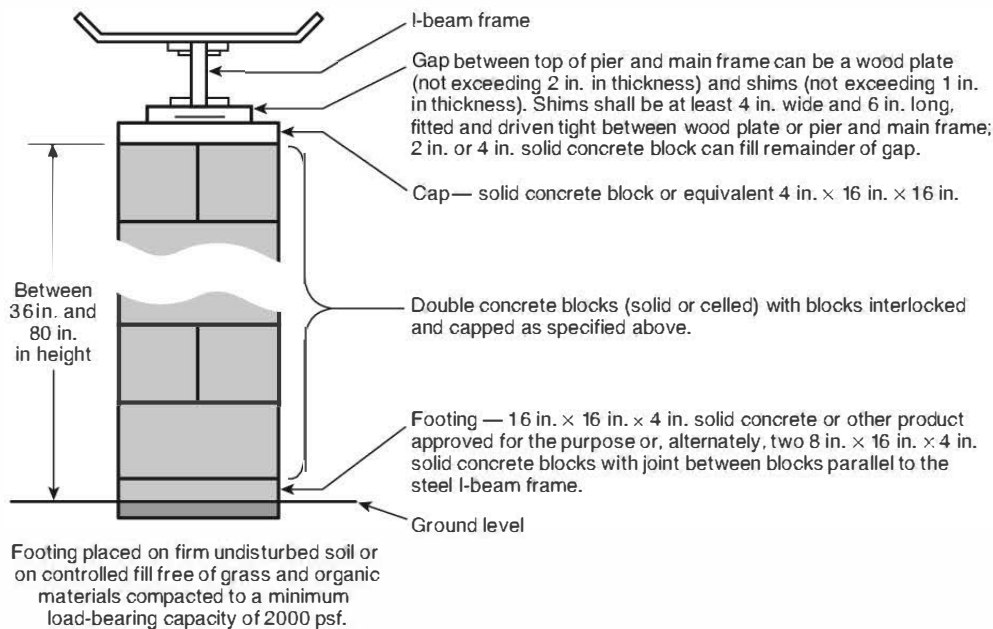

Note: For SI units, 1 in. = 25.4 mm, 1 psf = 0.04788 kN/m<sup>2</sup>.

**FIGURE 6.2.2.1(b) Typical Footing and Pier Installation — Greater than or Equal to 36 in. in Height.**

## 6.2.3 Design Requirements.

### 6.2.3.1 Load-Bearing Capacity.

**6.2.3.1.1** The load that each pier must carry shall depend on such factors as the dimensions of the home, the roof live load, the spacing of the piers, and the way the piers are used to support the home.

**6.2.3.1.2** Center beam/marriage wall blocking shall be required for multisection homes in accordance with Table 6.2.3.1.2(a) or Table 6.2.3.1.2(b).

### 6.2.3.1.3 Pier Capacities.

**6.2.3.1.3.1** Table 6.2.3.1.2(a) and Table 6.2.3.1.2(b) for pier capacities shall be used when the manufacturer's installation instructions are not available.

**Table 6.2.3.1.2(a) Minimum Pier Capacity, Frame Plus Perimeter Blocking (Both Frame and Perimeter Blocking Required)**

| Section Width(ft) | Roof Live Load (psf) | Pier Location | Minimum Pier Capacity (lb)      |                                 |                                 |                                  |
|-------------------|----------------------|---------------|---------------------------------|---------------------------------|---------------------------------|----------------------------------|
|                   |                      |               | At Maximum Pier Spacing of 4 ft | At Maximum Pier Spacing of 6 ft | At Maximum Pier Spacing of 8 ft | At Maximum Pier Spacing of 10 ft |
| 8                 | 20                   | Frame         | 900                             | 1,300                           | 1,800                           | 2,200                            |
|                   |                      | Perimeter     | 600                             | 800                             | 1,100                           | 1,400                            |
|                   | 30                   | Frame         | 900                             | 1,300                           | 1,800                           | 1,200                            |
|                   |                      | Perimeter     | 700                             | 1,100                           | 1,400                           | 1,800                            |
|                   | 40                   | Frame         | 900                             | 1,300                           | 1,800                           | 2,200                            |
|                   |                      | Perimeter     | 900                             | 1,300                           | 1,800                           | 2,200                            |
| 10                | 20                   | Frame         | 1,100                           | 1,700                           | 2,200                           | 2,800                            |
|                   |                      | Perimeter     | 700                             | 1,100                           | 1,400                           | 1,800                            |
|                   | 30                   | Frame         | 1,100                           | 1,700                           | 2,200                           | 2,800                            |
|                   |                      | Perimeter     | 900                             | 1,400                           | 1,800                           | 2,300                            |
|                   | 40                   | Frame         | 1,100                           | 1,700                           | 2,200                           | 2,800                            |
|                   |                      | Perimeter     | 1,100                           | 1,700                           | 2,200                           | 2,800                            |
| 12                | 20                   | Frame         | 1,300                           | 1,900                           | 2,600                           | 3,200                            |
|                   |                      | Perimeter     | 800                             | 1,200                           | 1,600                           | 2,000                            |
|                   | 30                   | Frame         | 1,300                           | 1,900                           | 2,600                           | 3,200                            |
|                   |                      | Perimeter     | 1,100                           | 1,600                           | 2,100                           | 2,600                            |
|                   | 40                   | Frame         | 1,300                           | 1,900                           | 2,600                           | 3,200                            |
|                   |                      | Perimeter     | 1,300                           | 1,900                           | 2,600                           | 3,200                            |
| 14                | 20                   | Frame         | 1,500                           | 2,200                           | 3,000                           | 3,700                            |
|                   |                      | Perimeter     | 900                             | 1,400                           | 1,900                           | 2,400                            |
|                   | 30                   | Frame         | 1,500                           | 2,200                           | 3,000                           | 3,700                            |
|                   |                      | Perimeter     | 1,200                           | 1,800                           | 2,400                           | 3,000                            |
|                   | 40                   | Frame         | 1,500                           | 2,200                           | 3,000                           | 3,700                            |
|                   |                      | Perimeter     | 1,500                           | 2,200                           | 3,000                           | 3,700                            |
| 16                | 20                   | Frame         | 1,700                           | 2,600                           | 3,400                           | 4,300                            |
|                   |                      | Perimeter     | 1,100                           | 1,600                           | 2,200                           | 2,700                            |
|                   | 30                   | Frame         | 1,700                           | 2,600                           | 3,400                           | 4,300                            |
|                   |                      | Perimeter     | 1,400                           | 2,100                           | 2,800                           | 3,500                            |
|                   | 40                   | Frame         | 1,700                           | 2,600                           | 3,400                           | 4,300                            |
|                   |                      | Perimeter     | 1,700                           | 2,600                           | 3,400                           | 4,300                            |
| 18                | 20                   | Frame         | 1,900                           | 2,900                           | 3,900                           | 4,800                            |
|                   |                      | Perimeter     | 1,200                           | 1,800                           | 2,500                           | 3,100                            |
|                   | 30                   | Frame         | 1,900                           | 2,900                           | 3,900                           | 4,800                            |
|                   |                      | Perimeter     | 1,600                           | 2,400                           | 3,200                           | 3,900                            |
|                   | 40                   | Frame         | 1,900                           | 2,900                           | 3,900                           | 4,800                            |
|                   |                      | Perimeter     | 1,900                           | 2,900                           | 3,900                           | 4,800                            |

For SI units, 1 ft = 0.3048 m, 1 psf = 0.04788 kN/m<sup>2</sup>, 1 lb = 4.448 N.

Notes:

(1) Frame blocking is the total of the frame weight plus perimeter weight.

(2) When using frame and perimeter blocking, the marriage lines of the multisection home are double the perimeter weight.

**Table 6.2.3.1.2(b) Minimum Pier Capacity, Multisection Pier Loading Under Marriage Line**

| Section Width (ft) | Roof Live Load (psf) | Pier Load and Minimum Pier Capacity (lb) |                                  |                                  |                                  |                                  |                                  |                                  |
|--------------------|----------------------|--|----------------------------------|----------------------------------|----------------------------------|----------------------------------|----------------------------------|----------------------------------|
|                    |                      | For Mating Wall Opening of 5 ft          | For Mating Wall Opening of 10 ft | For Mating Wall Opening of 15 ft | For Mating Wall Opening of 20 ft | For Mating Wall Opening of 25 ft | For Mating Wall Opening of 30 ft | For Mating Wall Opening of 35 ft |
| 8                  | 20                   | 600                                      | 1,200                            | 1,800                            | 2,400                            | 3,000                            | 3,600                            | 4,200                            |
|                    | 30                   | 800                                      | 1,600                            | 2,400                            | 3,200                            | 4,000                            | 4,800                            | 5,600                            |
|                    | 40                   | 1,000                                    | 2,000                            | 3,000                            | 4,000                            | 5,000                            | 5,000                            | 7,000                            |
| 10                 | 20                   | 800                                      | 1,500                            | 2,300                            | 3,000                            | 3,800                            | 4,500                            | 5,300                            |
|                    | 30                   | 1,000                                    | 2,000                            | 3,000                            | 4,000                            | 5,000                            | 6,000                            | 7,000                            |
|                    | 40                   | 1,300                                    | 2,500                            | 3,800                            | 5,000                            | 6,300                            | 7,500                            | 8,800                            |
| 12                 | 20                   | 900                                      | 1,800                            | 2,600                            | 3,500                            | 4,400                            | 5,300                            | 6,100                            |
|                    | 30                   | 1,200                                    | 2,300                            | 3,500                            | 4,700                            | 5,800                            | 7,000                            | 8,200                            |
|                    | 40                   | 1,500                                    | 2,900                            | 4,400                            | 5,800                            | 7,300                            | 8,800                            | 10,200                           |
| 14                 | 20                   | 1,000                                    | 2,000                            | 3,000                            | 4,100                            | 5,100                            | 6,100                            | 7,100                            |
|                    | 30                   | 1,400                                    | 2,700                            | 4,100                            | 5,400                            | 6,800                            | 8,100                            | 9,500                            |
|                    | 40                   | 1,700                                    | 3,400                            | 5,100                            | 6,800                            | 8,400                            | 10,100                           | 11,800                           |
| 16                 | 20                   | 1,200                                    | 2,300                            | 3,500                            | 4,700                            | 5,800                            | 7,000                            | 8,100                            |
|                    | 30                   | 1,600                                    | 3,100                            | 4,700                            | 6,200                            | 7,800                            | 9,300                            | 10,900                           |
|                    | 40                   | 1,900                                    | 3,800                            | 5,800                            | 7,500                            | 9,700                            | 11,600                           | 13,600                           |

For SI units, 1 ft = 0.3048 m, 1 psf = 0.04788 kN/m<sup>2</sup>, 1 lb = 4.448 N.

**Notes:**

(1) **Example:** For a 14 ft section width, 30 psf roof live load, and 18 ft wide mating wall opening, follow down the "Section Width" column to 14 ft. Follow across to 30 psf in the "Roof Live Load" column. Since the mating wall opening is 18 ft wide, follow across to the column headed "20." (For any opening width that is not shown, use the next higher number on the chart.) The required pier capacity is 5400 lb.

(2) Sidewall opening pier capacity is one-half the mating wall opening weight of an identical or next larger span. For piers supporting two adjacent openings, the capacity is the combination of the weights from each opening.

**6.2.3.1.3.2** Manufactured piers shall be rated at least to the capacities given in Table 6.2.3.1.2(a) and Table 6.2.3.1.2(b), and locally constructed piers shall be designed to transmit these loads safely as required by 6.2.3.2.

**6.2.3.2 Configuration.**

**6.2.3.2.1 Concrete Blocks.**

**6.2.3.2.1.1\*** Concrete block piers shall be installed in accordance with Figure 6.2.2.1(a) and Figure 6.2.2.1(b).

**6.2.3.2.1.2** Load-bearing (not decorative) concrete blocks shall have nominal dimensions of at least 8 in. × 8 in. × 16 in. (205 mm × 205 mm × 410 mm).

**6.2.3.2.1.3** The concrete blocks shall be stacked with their hollow cells aligned vertically.

**6.2.3.2.1.4** When piers are constructed of blocks stacked side by side, each layer shall be at right angles to the preceding one, as shown in Figure 6.2.2.1(a) and Figure 6.2.2.1(b).

**6.2.3.2.2 Caps.**

**6.2.3.2.2.1** Structural loads shall be evenly distributed across capped hollow block piers, as shown in Figure 6.2.2.1(a) and Figure 6.2.2.1(b).

**6.2.3.2.2.2** Caps shall be of solid masonry of at least 4 in. (100 mm) nominal thickness, or of dimensional lumber at least 2 in. (50 mm) nominal thickness, or of steel.

**6.2.3.2.2.3** All caps shall be of the same length and width as the piers on which they rest.

**6.2.3.2.3 Gaps.**

**6.2.3.2.3.1** Nominal 4 in. × 6 in. (100 mm × 150 mm) shims shall be used to level the home and fill any gaps between the base of the I-beam and the top of the pier cap.

**6.2.3.2.3.2** Shims shall be used in pairs as shown in Figure 6.2.2.1(a) and Figure 6.2.2.1(b), and shims shall be driven in tightly so that they do not occupy more than 1 in. (25 mm) of vertical space.

**6.2.3.2.3.3** Wood plates no thicker than 2 in. (50 mm) shall be used to fill in any remaining vertical gaps.

**6.2.3.2.4 Pier Heights.** Manufactured pier heights shall be selected so that the adjustable risers do not extend more than 2 in. (50 mm) when finally positioned.

**6.2.3.3 Clearance Under Homes.**

**6.2.3.3.1** A minimum clearance of 12 in. (305 mm) shall be maintained beneath the lowest member of the main frame (I-beam or channel beam) in the area of utility connections.

**6.2.3.3.2** No more than 25 percent of the lowest member of the main frame of the home shall be less than 12 in. (305 mm) above grade.

6.2.3.4 All cap and shim materials within 18 in. (455 mm) of the ground shall be preservative-treated wood, naturally durable wood species, or equivalent.

## 6.2.4 Design Procedures for Concrete Block Piers.

### 6.2.4.1 Piers Less Than 36 in. (915 mm) High.

6.2.4.1.1 Piers less than 36 in. (915 mm) high shall be permitted to be constructed of single, open, or closed-cell concrete blocks, 8 in.  $\times$  8 in.  $\times$  16 in. (205 mm  $\times$  205 mm  $\times$  410 mm).

6.2.4.1.2 The piers shall be installed so that the long sides are at right angles to the supported I-beam, as shown in Figure 6.2.2.1(a) and Figure 6.2.2.1(b).

6.2.4.1.3 Open cells shall be positioned at right angles to the footers.

6.2.4.1.4 Horizontal offsets shall not exceed  $\frac{1}{2}$  in. (13 mm) top to bottom.

6.2.4.1.5\* Mortar shall not normally be required.

6.2.4.1.6 Manufactured piers shall be listed and labeled.

6.2.4.2 Piers 36 in. (915 mm) to 80 in. (2030 mm) High and Corner Piers. All piers between 36 in. (915 mm) and 80 in. (2030 mm) high and all corner piers over three blocks high shall be constructed out of double, interlocked concrete blocks as shown in Figure 6.2.2.1 (a) and in Figure 6.2.2.1 (b).

6.2.4.3 Piers over 80 in. (2030 mm) High. Piers over 80 in. (2030 mm) high shall be designed by a registered professional engineer.

6.2.4.4 Elevated Homes. When more than one-fourth of the area of a home is installed so that the bottom of the main frame members are more than 36 in. (915 mm) above ground level, the home stabilizing devices shall be designed by a qualified registered professional engineer.

## 6.2.5 Location and Spacing.

6.2.5.1 The location and spacing of piers shall depend upon the dimensions and weight of the home, the roof load zone, the type of construction (single- or multisection), and such other factors as the location of doors or other openings.

6.2.5.2 Piers shall be no more than 2 ft (610 mm) from either end and not more than 10 ft (3048 mm) center to center under the main frame beam.

6.2.5.3\* **Single-Section Homes.** The recommended location and spacing of piers for a single-section home shown in Figure 6.2.5.3 shall be used when the manufacturer's installation instructions are not available.

6.2.5.4\* **Multisection Homes.** The recommended location and spacing of piers for a multisection home shown in Figure 6.2.5.4 shall be used when the manufacturer's installation instructions are not available.

6.2.5.5\* **Perimeter Blocking.** Supports shall be placed on both sides of side wall exterior doors and any other side wall openings greater than 48 in. (1220 mm) (such as entry and sliding glass doors), and under porch posts, factory installed fireplaces, and wood stoves.

6.3 **Footings.** Footing materials shall conform to Section 6.3, and other materials approved for footings shall be permitted to be used when approved by the AHJ if they provide equal load-bearing capacity and resistance to decay. Footings shall be placed on undisturbed soil or compacted fill. Every pier shall be supported by a footing.

### 6.3.1 Acceptable Types of Footings.

6.3.1.1 **Concrete.** Footings shall be permitted to consist of either of the following:

- (1) 4 in. (100 mm) nominal precast concrete pads meeting or exceeding ASTM C90, *Standard Specification for Load-bearing Concrete Masonry Units*, without reinforcement, with at least a 28-day compressive strength of 3000 psi (20.7 MN/m<sup>2</sup>)
- (2) 6 in. (150 mm) cast-in-place concrete pads, slabs, or ribbons with at least a 28-day compressive strength of 3000 psi (20.7 MN/m<sup>2</sup>)

Required perimeter support (see Note 4);  
existing patio door or addition of patio door

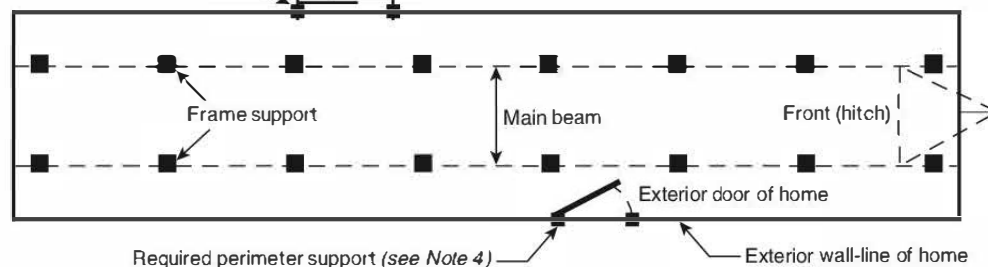

Notes:

- (1) See Table 6.2.3.1.2(a) for required pier capacity and spacing.
- (2) See Table 6.2.3.1.2(b) and Section 6.3 for footing requirements.
- (3) Locate piers a maximum of 24 in. (610 mm) from both ends.
- (4) Place piers on both sides of entry doors, at any other openings greater than 48 in. (1220 mm) width, such as patio or atrium doors, and under porch posts, factory-installed fireplaces, and wood stoves.

FIGURE 6.2.5.3 Typical Blocking Diagram for Single Section.

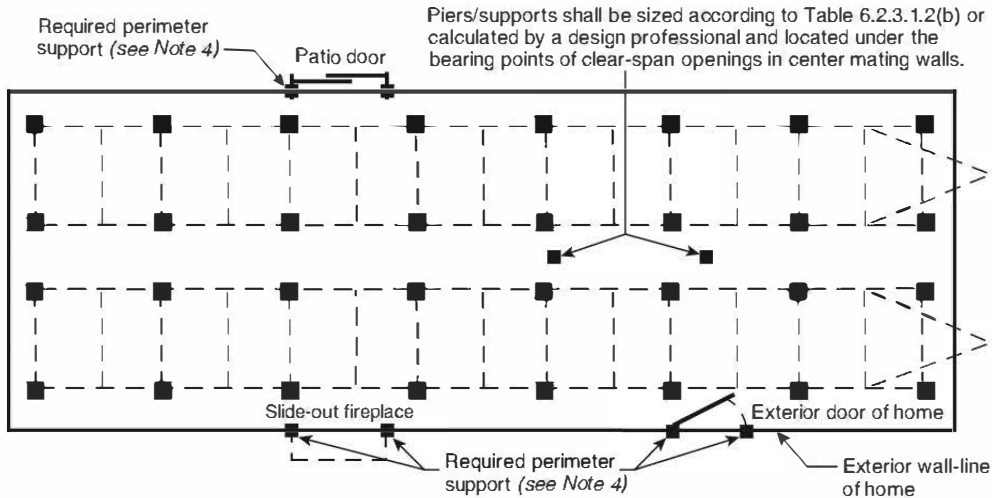

## Notes:

- (1) See Table 6.2.3.1.2(a) for required pier capacity and spacing.
- (2) See Table 6.2.3.1.2(b) and Section 6.3 for footing requirements.
- (3) Locate piers a maximum of 24 in. (610 mm) from both ends.
- (4) Place piers on both sides of entry doors, at any other openings greater than 48 in. (1220 mm) width, such as patio or atrium doors, and under porch posts, factory-installed fireplaces, and wood stoves.

**FIGURE 6.2.5.4** Typical Blocking Diagram for Multisection Homes.

### 6.3.1.2 Pressure-Treated Permanent Wood.

**6.3.1.2.1** A minimum of two layers of nominal 2 in. (50 mm) thick pressure-treated wood having 0.60 pcf (94 N/m<sup>3</sup>) retention, with the long dimensions of the second layer placed under the pier and perpendicular to that of the first layer, shall be used.

**6.3.1.2.2** Pressure-treated footings shall be permitted to consist of nominal 2 in. (50 mm) thick pressure-treated wood or a single layer of a minimum thickness of 3/4 in. (19 mm) and a maximum size of 16 in. × 16 in. (410 mm × 410 mm), or, for larger sizes, two pieces of nominal 3/4 in. thick (2 3/32 actual) (19 mm) plywood (APA-rated sheathing, exposure 1, PS1) pressure-treated for soil contact.

### 6.3.1.3 ABS Footing Pads.

**6.3.1.3.1** ABS footing pads shall be permitted in accordance with pad manufacturer installation instructions.

**6.3.1.3.2** ABS footing pads shall be listed or labeled for the required load capacity.

### 6.3.2 Placement in Freezing Climates.

**6.3.2.1 Conventional Footings.** Footings placed in freezing climates shall comply with 6.3.2.1.1, 6.3.2.1.2, or 6.3.2.1.3.

**6.3.2.1.1** In areas subject to ground frost heave, footings shall be placed below the frost line.

**6.3.2.1.2** Local authorities shall be consulted to determine the depth of the frost line.

**6.3.2.1.3** In the absence of a local code, the frost penetration map provided in Figure 6.3.2.1.3 shall be used as a guide.

### 6.3.2.2 Floating Slab Systems.

**6.3.2.2.1** When properly designed by a registered professional engineer, a “floating slab system” shall be permitted to be used above the frost line.

**6.3.2.2.2** The design shall accommodate the anchorage requirements identified in Section 7.5.

### 6.3.2.3\* Insulated Foundations.

**6.3.2.3.1** Footings shall be permitted to be placed above the frost line when the home is provided with a perimeter foundation or skirting having insulation properties sufficient to prevent freezing of the soil under or adjacent to every load-bearing component of the foundation and acceptable for this purpose to the authority having jurisdiction.

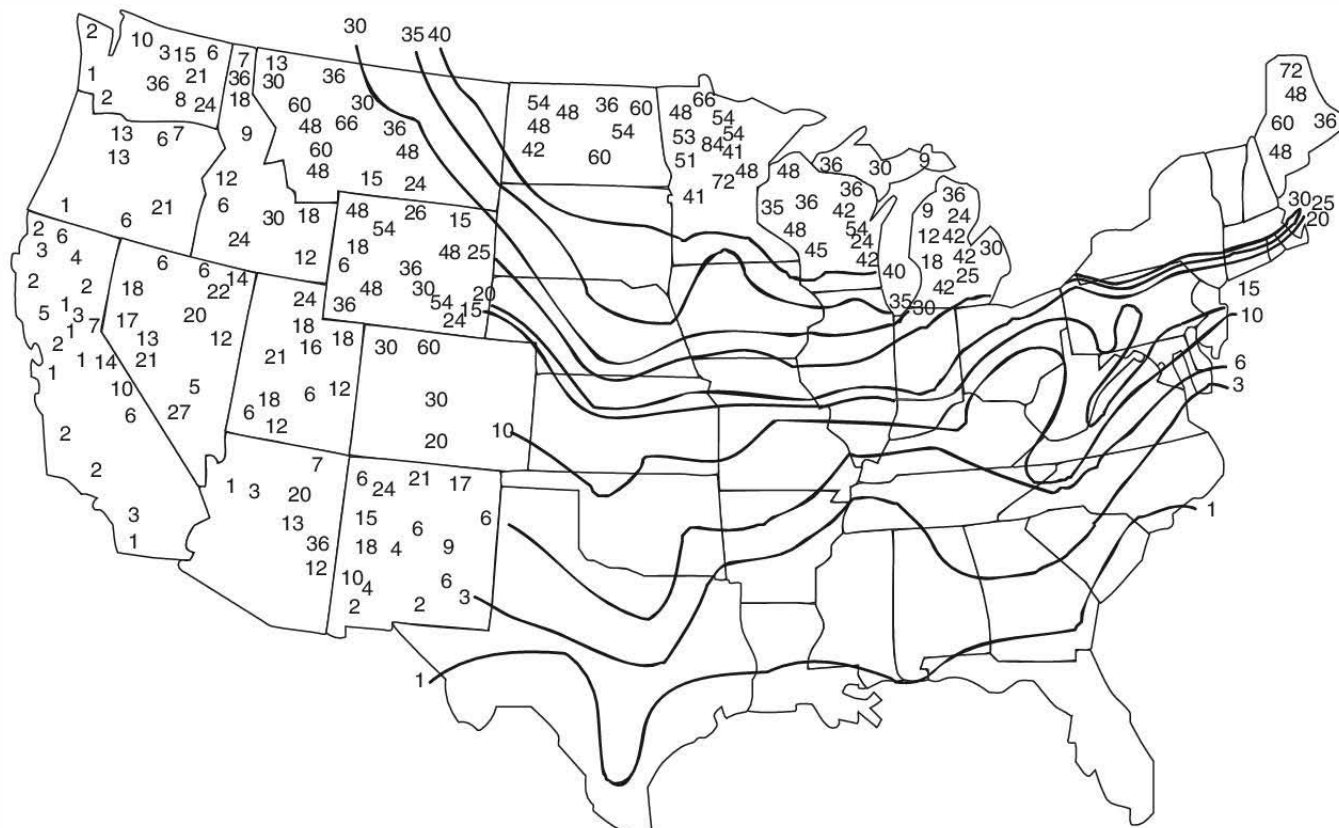

Note: Numbers are inches below ground level (for SI units, 1 in. = 25.4 mm).

**FIGURE 6.3.2.1.3 Frost Penetration Map.**

**6.3.2.3.2** Insulation systems shall be compatible with the requirement to cross-ventilate the entire space under the home.

**6.3.3\* Sizing of Footings.** The sizing of footings depends on the load-bearing capacity of both the piers and the soil. It shall be permitted to construct footings in accordance with Table 6.3.3.

**6.3.4\* Combination Systems.** Support systems that combine both load-bearing capacity and uplift resistance shall also be sized for the applicable design loads.

#### **6.4 Permanent Foundations.**

**6.4.1** Designs for permanent foundations (such as basements, crawl spaces, or load-bearing perimeter foundations) shall be designed by a registered professional engineer and constructed in accordance with local codes.

**6.4.2** When no such design is available from the home manufacturer or covered in the state building code, a registered professional engineer shall be consulted in order to obtain a design to satisfy the house support requirements.

#### **6.5 Special Considerations.**

**6.5.1 Severe Climatic Conditions.** The provisions of 7.5.4 shall be required when the conditions in 7.5.4 exist at the home installation site.

**6.5.2 Special Snow Load Conditions.** Homes designed for and located in areas with roof live loads greater than 40 psf (1.9 kPa) shall be installed according to the home manufacturer's installation instructions or designed by a registered professional engineer.

Table 6.3.3 Footing Size

| Soil Capacity (psf) | Minimum Footing Size (in.) | Single Stack Pier (8 in. x 16 in.) |  | Double Stack Pier (16 in. x 16 in.) |  |   |
|---------------------|----------------------------|------------------------------------|--|-------------------------------------|--|---|
|                     |                            | Maximum Footing Capacity (lb)      | Unreinforced Cast-in-Place Minimum Thickness (in.) | Maximum Footing Capacity (lb)       | Unreinforced Cast-in-Place Minimum Thickness (in.) |   |
| 1,000               | 16 x 16                    | 1,600                              | 6  | 1,600                               | 6  |   |
|                     | 20 x 20                    | 2,600                              | 6  | 2,600                               | 6  |   |
|                     | 24 x 24                    | 3,700                              | 6  | 3,700                               | 6  |   |
|                     | 30 x 30                    | 5,600                              | 8  | 5,800                               | 6  |   |
|                     | 36 x 36                    | 7,900                              | 10   | 8,100                               | 8  |   |
|                     | 42 x 42                    | 10,100                             | 12   | 10,700                              | 10   |   |
|                     | 48 x 48                    | 13,000                             | 15   | 13,600                              | 12   |   |
| 1,500               | 16 x 16                    | 2,500                              | 6  | 2,500                               | 6  |   |
|                     | 20 x 20                    | 4,000                              | 6  | 4,000                               | 6  |   |
|                     | 24 x 24                    | 5,600                              | 8  | 5,700                               | 6  |   |
|                     | 30 x 30                    | 8,600                              | 10   | 8,900                               | 6  |   |
|                     | 36 x 36                    | 12,200                             | 12   | 12,600                              | 8  |   |
|                     | 42 x 42                    | 16,100                             | 15   | 16,500                              | 12   |   |
|                     | 48 x 48                    | 20,400                             | 18   | 21,000                              | 15   |   |
| 2,000               | 16 x 16                    | 3,400                              | 6  | 3,400                               | 6  |   |
|                     | 20 x 20                    | 5,300                              | 6  | 5,300                               | 6  |   |
|                     | 24 x 24                    | 7,600                              | 8  | 7,700                               | 6  |   |
|                     | 30 x 30                    | 11,600                             | 10   | 11,900                              | 8  |   |
|                     | 36 x 36                    | 16,300                             | 15   | 16,900                              | 10   |   |
|                     | 42 x 42                    | 21,700                             | 18   | 22,700                              | 12   |   |
|                     | 2,500                      | 16 x 16                            | 4,300  | 6                                   | 4,300  | 6 |
| 20 x 20             |                            | 6,700                              | 6  | 6,700                               | 6  |   |
| 24 x 24             |                            | 9,600                              | 8  | 9,700                               | 6  |   |
| 30 x 30             |                            | 14,700                             | 12   | 15,000                              | 8  |   |
| 36 x 36             |                            | 20,800                             | 15   | 21,400                              | 10   |   |
| 3,000               |                            | 16 x 16                            | 5,200  | 6                                   | 5,200  | 6 |
|                     |                            | 20 x 20                            | 8,100  | 8                                   | 8,100  | 6 |
|                     | 24 x 24                    | 11,500                             | 10   | 11,700                              | 6  |   |
|                     | 30 x 30                    | 17,800                             | 12   | 18,100                              | 8  |   |
|                     | 36 x 36                    | 25,000                             | 18   | 25,700                              | 12   |   |
|                     | 4,000                      | 16 x 16                            | 7,000  | 6                                   | 7,000  | 6 |
|                     |                            | 20 x 20                            | 10,800   | 8                                   | 10,900   | 6 |
| 24 x 24             |                            | 15,500                             | 10   | 15,600                              | 8  |   |
| 30 x 30             |                            | 23,800                             | 15   | 24,200                              | 10   |   |

For SI units, 1 psf = 0.04788 kN/m<sup>2</sup>, 1 in. = 25.4 mm, 1 lb = 4.448 N.

Notes:

(1) The footing sizes shown are for square pads and are based on the area (in.<sup>2</sup>), shear, and bending required for the loads shown. Other configurations, such as rectangular configurations, can be used, provided the area is equal to or greater than the area of the square footing shown in the table and the distance from the edge of the pier to the edge of the footing is not exceeded.

(2) The 6 in. cast-in-place values can be used for 4 in. unreinforced precast concrete footings.

(3) The capacity values listed have been reduced by the dead load of the concrete footing.

**Chapter 7 Installation Procedures**

**7.1\* Before Moving Manufactured Home to Location.** The site shall be prepared in accordance with Chapter 5, and utilities shall be available when required by the AHJ.

**7.2\* Positioning of Home.** The home shall be installed and leveled by qualified licensed installation personnel who are acceptable to the AHJ.

**7.3\* Interconnection of Multisection Homes.** The interconnection of multisection homes shall be completed in accordance with the manufacturer's installation instructions. When the manufacturer's installation instructions are not available, the interconnection of multisection homes shall be in accordance with the AHJ.

**7.4 Crossover Connections for Multisection Manufactured Homes.**

**7.4.1 Utility Crossovers.** Water, drainage, gas, electricity, and telephone utility crossovers shall be connected as outlined in Chapter 10.

**7.4.2 Ductwork Crossovers.**

**7.4.2.1** Metal plumber's tape, galvanized metal straps, or plastic tape shall be used around the duct collar and secured tightly.

**7.4.2.2** If metal straps are used, they shall be secured with sheet metal screws.

**7.4.2.3** The duct shall be fastened to the collar with a minimum of three sheet metal screws equally spaced around the collar.

**7.4.2.4** The flexible air-conditioning or heating ducts shall be installed in accordance with the duct manufacturer's instructions.

**7.4.2.5** The duct shall be suspended or supported above the ground and arranged under the floor to minimize compression or kinking in any location, as shown in Figure 7.4.2.5(a) and Figure 7.4.2.5(b). In-floor crossover ducts shall be permitted in accordance with 7.4.2.7.

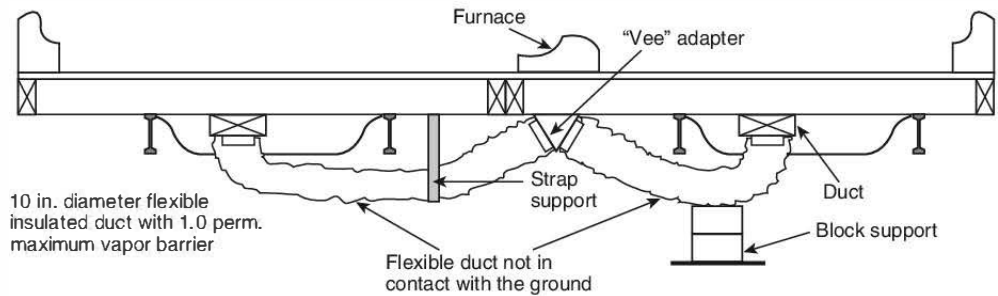

Notes:

- (1) This system is utilized when a crossover duct has not been built into the floor and the furnace is outside the I-beam. With this type of installation, it is necessary for two flexible ducts to be installed.
- (2) For SI units, 1 in. = 25.4 mm

**FIGURE 7.4.2.5(a) Crossover Duct Installation (Option 1).**

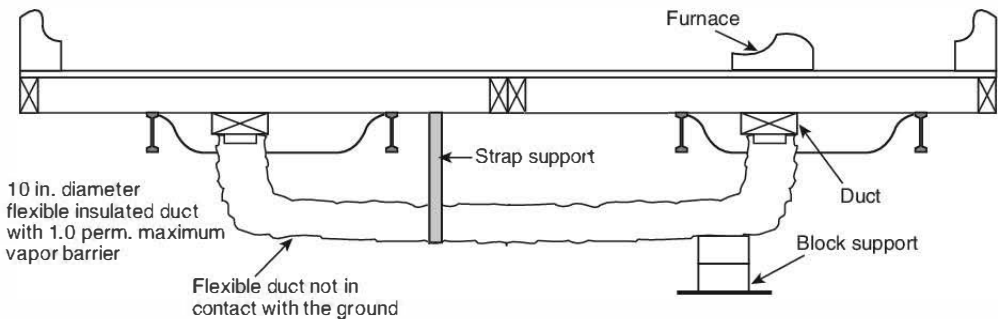

Notes:

- (1) This system is used when a crossover duct has not been built into the floor and the furnace is situated directly over the main duct in one section of the home. A single flexible duct is then used to connect the two sections to each other.
- (2) For SI units, 1 in. = 25.4 mm.

**FIGURE 7.4.2.5(b) Crossover Duct Installation (Option 2).**



**7.4.2.6** Exposed crossover ducts shall be insulated with materials having a minimum R-8 value.

**7.4.2.7** The in-floor crossover duct connection shall be permitted to be installed per the manufacturer's installation instructions or sealed with foam tape prior to joining sections of the home.

## 7.5 Anchoring Instructions.

### 7.5.1 Security Against the Wind.

**7.5.1.1** After blocking and leveling, the installer shall secure the manufactured home against the wind, unless the AHJ permits otherwise.

**7.5.1.2** The type of installation shall be the determining factor in deciding how the manufactured home shall be secured against the wind as described in 7.5.2 and 7.5.3.

**7.5.1.3** Use of ground anchors is not required for homes located in areas having a 3-second gust basic wind speed of 90 mph (40.2 m/sec) or less, provided the support system meets the prescriptive seismic requirements of Chapter 13.

### 7.5.2\* Normal Installations.

**7.5.2.1** The anchoring and foundation system shall be capable of meeting the loads required by ASCE/SEI 7, *Minimum Design Loads for Buildings and Other Structures*. The wind zone designation shall be based on the location where the manufactured home is sited per 6.5.3.2 of NFPA 501.

**7.5.2.2** When using another type of installation that is not listed in accordance with 3.2.4, a registered professional engineer shall be consulted.

### 7.5.2.3 Specifications for Tie-Down Straps and Anchors.

**7.5.2.3.1 Anchors.** The working load of anchors and anchoring equipment shall be certified by a registered professional engineer, architect, or nationally recognized testing laboratory.

**7.5.2.3.1.1** Ground anchors shall be certified for use in the soil classification where the home is located.

**7.5.2.3.1.2** Homes placed in flood hazard areas per 3.3.11 shall utilize ground anchors certified for use in the soil classification where the home is located under saturated soil conditions.

**7.5.2.3.2 Tie-Down Straps.** A minimum of 1¼ in. × 0.035 in. (32 mm × 0.9 mm) zinc coating 0.30 oz/ft<sup>2</sup> (0.094 kg/m<sup>2</sup>) steel strapping conforming to ASTM D3953, *Standard Specification for Strapping, Flat Steel and Seals, Type 1, Grade 1, Finish B* with a minimum total capacity of 4725 lb (21.0 kN) and a working capacity of 3150 lb (14.0 kN) shall be used. Slit or cut edges of coated strapping shall not be required to be zinc coated.

### 7.5.2.4 Number and Location of Anchors.

**7.5.2.4.1 Transverse Anchorage.** The number and location of anchors and anchor straps for securing single-section and multisection manufactured homes in the transverse direction shall conform to the manufacturer's installation instructions.

**7.5.2.4.1.1** When relocating the home or when the manufacturer's installation instructions are not available, the number and location of anchors and anchor straps securing single-section and multisection manufactured homes in the transverse direction shall conform to Table 7.5.2.4.1.1(a) through Table

7.5.2.4.1.1(d) and Figure 7.5.2.4.1.1(a) through Figure 7.5.2.4.1.1(c), subject to the limitations of the notes of Table 7.5.2.4.1.1(a) through Table 7.5.2.4.1.1(d).

**7.5.2.4.1.2** Transverse straps for homes placed in NFPA 501 Wind Zone I shall be connected per Figure 7.5.2.4.1.1(b).

**7.5.2.4.1.3** Transverse straps for homes placed in NFPA 501 Wind Zones II, III, and IV shall be connected per Figure 7.5.2.4.1.1(c), subject to the limitations.

**7.5.2.4.2 Longitudinal Anchorage.** Manufactured homes shall have anchors to resist longitudinal forces.

**7.5.2.4.2.1** The number and location of anchors and anchor straps for securing single-section and multisection manufactured homes in the longitudinal direction shall conform to the manufacturer's installation instructions.

**7.5.2.4.2.2** When relocating the home or when the manufacturer's installation instructions are not available, the number and location of anchors and anchor straps securing single-section and multisection manufactured homes in the longitudinal direction shall conform to Table 7.5.2.4.2.2.

**7.5.2.4.2.3** Anchors shall be secured to each manufactured home frame or as specified in the manufacturer's installation instructions.

**7.5.2.4.2.4** When longitudinal anchorage is provided per Table 7.5.2.4.2.2, the angle between the longitudinal anchor strap and the frame shall be between 30 and 45 degrees.

### 7.5.2.4.3 Anchor Installation.

**7.5.2.4.3.1** Soil classification shall be determined using either a soil torque probe or locally accepted values approved by the AHJ.

**7.5.2.4.3.2** The installed anchor shall be certified to produce a working load that meets or exceeds the anchor strength listed in Table 7.5.2.4.1.1(a) through Table 7.5.2.4.1.1(d) for the soil class for which it is listed and approved by the AHJ.

**7.5.2.4.3.3** Where required by the anchor certification, all anchors shall be installed with the stabilizer plates in accordance with their listing and the anchor manufacturer's installation instructions.

**7.5.2.4.3.4** Stabilizer plates shall not be required for anchors certified for use without stabilizer plates.

**7.5.2.4.4** Each anchor shall be manufactured and installed in accordance with its listing by a nationally recognized testing agency, which shall list the anchor for use in a classified soil based on a nationally recognized testing protocol.

**7.5.3 Sidewall or Over-the-Roof Straps.** If sidewall or over-the-roof straps are installed on the home, they shall be connected to an anchoring device, or an alternate method shall be provided that enables the home to meet this requirement.

### 7.5.4 Severe Climatic Conditions.

**7.5.4.1 Freezing Climates.** In frost-susceptible soils or high water table locations, anchor augers shall be installed below the frost line or in accordance with a design by a registered professional engineer.

**Table 7.5.2.4.1.1(a) Maximum Ground Anchor Spacing for NFPA Wind Zone I (90 mph)**

| Anchor Strength (lb) | Pier Height (in.) | Roof Pitch | Building Width — Single Unit |      |                      |      |                      |      | Building Width — Double Unit |      |                      |      |                      |      |
|----------------------|-------------------|------------|------------------------------|------|----------------------|------|----------------------|------|------------------------------|------|----------------------|------|----------------------|------|
|                      |                   |            | 12 ft                        |      | 14 ft                |      | 16 ft                |      | 24 ft                        |      | 28 ft                |      | 32 ft                |      |
|                      |                   |            | I-Beam Spacing (in.)         |      | I-Beam Spacing (in.) |      | I-Beam Spacing (in.) |      | I-Beam Spacing (in.)         |      | I-Beam Spacing (in.) |      | I-Beam Spacing (in.) |      |
|                      |                   |            | 82.5                         | 99.5 | 82.5                 | 99.5 | 82.5                 | 99.5 | 82.5                         | 99.5 | 82.5                 | 99.5 | 82.5                 | 99.5 |
| 1500                 | 25                | 3:12       | 9                            | 9.3  | 9.4                  | 9.6  | 9.8                  | 9.9  | 8.8                          | 7.1  | 10.3                 | 9.4  | 11.1                 | 10.6 |
|                      |                   | 5:12       | 9.1                          | 9.3  | 9.5                  | 9.7  | 9.7                  | 9.9  | 7.4                          | 6    | 8.4                  | 7.7  | 8.8                  | 8.5  |
|                      |                   | 7:12       | 8.5                          | 8.7  | 8.7                  | 8.9  | 8.8                  | 9    | 6.5                          | 5.3  | 7.2                  | 6.6  | 7.5                  | 7.2  |
|                      | 33                | 3:12       | 8.7                          | 8.9  | 9.1                  | 9.3  | 9.5                  | 9.7  | 7.6                          | 5.9  | 9.3                  | 8.3  | 10.4                 | 9.8  |
|                      |                   | 5:12       | 8.8                          | 9    | 9.2                  | 9.4  | 9.5                  | 9.7  | 6.4                          | 4.9  | 7.6                  | 6.7  | 8.2                  | 7.7  |
|                      |                   | 7:12       | 8.2                          | 8.5  | 8.5                  | 8.7  | 8.6                  | 8.8  | 5.6                          | 4.3  | 6.6                  | 5.8  | 7                    | 6.6  |
|                      | 41                | 3:12       | 8.4                          | 8.6  | 8.8                  | 9.1  | 9.2                  | 9.4  | 6.6                          | 4.9  | 8.4                  | 7.3  | 9.6                  | 8.9  |
|                      |                   | 5:12       | 8.5                          | 8.7  | 8.9                  | 9.1  | 9.2                  | 9.4  | 5.5                          | 4.1  | 6.9                  | 5.9  | 7.6                  | 7.1  |
|                      |                   | 7:12       | 7.9                          | 8.2  | 8.2                  | 8.4  | 8.4                  | 8.6  | 4.9                          | 3.6  | 5.9                  | 5.1  | 6.5                  | 6    |
|                      | 48                | 3:12       | 8.1                          | 8.4  | 8.6                  | 8.8  | 9                    | 9.2  | 5.9                          | 4.3  | 7.7                  | 6.5  | 9                    | 8.2  |
|                      |                   | 5:12       | 8.2                          | 8.5  | 8.6                  | 8.9  | 9                    | 9.2  | 4.9                          | 3.6  | 6.3                  | 5.3  | 7.1                  | 6.5  |
|                      |                   | 7:12       | 7.7                          | 8    | 8                    | 8.2  | 8.2                  | 8.4  | 4.3                          | 3.2  | 5.4                  | 4.6  | 6.1                  | 5.5  |
| 2000                 | 25                | 3:12       | 12                           | 12.3 | 12.6                 | 12.8 | 13                   | 13.2 | 11.8                         | 9.5  | 13.7                 | 12.6 | 14.8                 | 14.2 |
|                      |                   | 5:12       | 12.1                         | 12.4 | 12.6                 | 12.9 | 13                   | 13.2 | 9.9                          | 8    | 11.2                 | 10.3 | 11.8                 | 11.3 |
|                      |                   | 7:12       | 11.3                         | 11.6 | 11.6                 | 11.9 | 11.8                 | 12   | 8.7                          | 7    | 9.7                  | 8.9  | 10                   | 9.6  |
|                      | 33                | 3:12       | 11.6                         | 11.9 | 12.2                 | 12.4 | 12.6                 | 12.9 | 10.2                         | 7.8  | 12.4                 | 11   | 13.8                 | 13   |
|                      |                   | 5:12       | 11.7                         | 12.1 | 12.2                 | 12.5 | 12.6                 | 12.9 | 8.5                          | 6.5  | 10.1                 | 9    | 11                   | 10.3 |
|                      |                   | 7:12       | 10.9                         | 11.3 | 11.3                 | 11.6 | 11.5                 | 11.8 | 7.5                          | 5.7  | 8.8                  | 7.8  | 9.3                  | 8.8  |
|                      | 41                | 3:12       | 11.2                         | 11.5 | 11.8                 | 12.1 | 12.3                 | 12.5 | 8.8                          | 6.6  | 11.2                 | 9.7  | 12.8                 | 11.8 |
|                      |                   | 5:12       | 11.3                         | 11.7 | 11.9                 | 12.2 | 12.3                 | 12.6 | 7.4                          | 5.5  | 9.1                  | 7.9  | 10.2                 | 9.4  |
|                      |                   | 7:12       | 10.5                         | 10.9 | 10.9                 | 11.3 | 11.2                 | 11.5 | 6.5                          | 4.8  | 7.9                  | 6.8  | 8.7                  | 8    |
|                      | 48                | 3:12       | 10.8                         | 11.2 | 11.4                 | 11.7 | 11.9                 | 12.2 | 7.9                          | 5.7  | 10.3                 | 8.7  | 12                   | 10.9 |
|                      |                   | 5:12       | 10.9                         | 11.3 | 11.5                 | 11.9 | 12                   | 12.3 | 6.6                          | 4.8  | 8.4                  | 7.1  | 9.5                  | 8.7  |
|                      |                   | 7:12       | 10.2                         | 10.6 | 10.6                 | 11   | 10.9                 | 11.2 | 5.8                          | 4.2  | 7.2                  | 6.1  | 8.1                  | 7.4  |
| 2500                 | 25                | 3:12       | 15.1                         | 15.4 | 15.7                 | 16   | 16.3                 | 16.5 | 14.7                         | 11.9 | 17.1                 | 15.7 | 18.5                 | 17.7 |
|                      |                   | 5:12       | 15.2                         | 15.6 | 15.8                 | 16.1 | 16.2                 | 16.5 | 12.4                         | 10   | 14                   | 12.8 | 14.7                 | 14.1 |
|                      |                   | 7:12       | 14.1                         | 14.5 | 14.5                 | 14.8 | 14.7                 | 15   | 10.8                         | 8.8  | 12.1                 | 11.1 | 12.5                 | 12   |
|                      | 33                | 3:12       | 14.5                         | 14.9 | 15.2                 | 15.6 | 15.8                 | 16.1 | 12.7                         | 9.8  | 15.5                 | 13.8 | 17.3                 | 16.3 |
|                      |                   | 5:12       | 14.6                         | 15.1 | 15.3                 | 15.7 | 15.8                 | 16.1 | 10.6                         | 8.2  | 12.7                 | 11.2 | 13.7                 | 12.9 |
|                      |                   | 7:12       | 13.7                         | 14.1 | 14.1                 | 14.5 | 14.4                 | 14.7 | 9.3                          | 7.2  | 10.9                 | 9.7  | 11.7                 | 11   |
|                      | 41                | 3:12       | 14                           | 14.4 | 14.7                 | 15.1 | 15.3                 | 15.7 | 11                           | 8.2  | 14                   | 12.1 | 16                   | 14.8 |
|                      |                   | 5:12       | 14.1                         | 14.6 | 14.8                 | 15.2 | 15.4                 | 15.7 | 9.2                          | 6.9  | 11.4                 | 9.9  | 12.7                 | 11.8 |
|                      |                   | 7:12       | 13.2                         | 13.6 | 13.7                 | 14.1 | 14                   | 14.4 | 8.1                          | 6    | 9.9                  | 8.5  | 10.8                 | 10   |
|                      | 48                | 3:12       | 13.6                         | 14   | 14.3                 | 14.7 | 14.9                 | 15.3 | 9.8                          | 7.2  | 12.8                 | 10.9 | 15                   | 13.6 |
|                      |                   | 5:12       | 13.7                         | 14.2 | 14.4                 | 14.8 | 15                   | 15.4 | 8.2                          | 6    | 10.5                 | 8.9  | 11.9                 | 10.8 |
|                      |                   | 7:12       | 12.8                         | 13.3 | 13.3                 | 13.7 | 13.7                 | 14.1 | 7.2                          | 5.3  | 9                    | 7.7  | 10.1                 | 9.2  |
| 3150                 | 25                | 3:12       | 19                           | 19.4 | 19.8                 | 20.2 | 20.5                 | 20.9 | 18.6                         | 15   | 21.6                 | 19.8 | 23.3                 | 22.4 |
|                      |                   | 5:12       | 19.1                         | 19.6 | 19.9                 | 20.3 | 20.4                 | 20.8 | 15.6                         | 12.6 | 17.6                 | 16.2 | 18.5                 | 17.8 |
|                      |                   | 7:12       | 17.8                         | 18.3 | 18.3                 | 18.7 | 18.6                 | 18.9 | 13.7                         | 11   | 15.2                 | 14   | 15.7                 | 15.1 |
|                      | 33                | 3:12       | 18.3                         | 18.8 | 19.2                 | 19.6 | 19.9                 | 20.3 | 16                           | 12.3 | 19.6                 | 17.4 | 21.8                 | 20.5 |
|                      |                   | 5:12       | 18.4                         | 19   | 19.3                 | 19.7 | 19.9                 | 20.3 | 13.4                         | 10.3 | 16                   | 14.2 | 17.3                 | 16.3 |
|                      |                   | 7:12       | 17.2                         | 17.7 | 17.7                 | 18.2 | 18.1                 | 18.5 | 11.8                         | 9    | 13.8                 | 12.2 | 14.7                 | 13.8 |
|                      | 41                | 3:12       | 17.6                         | 18.2 | 18.5                 | 19   | 19.3                 | 19.7 | 13.9                         | 10.3 | 17.7                 | 15.3 | 20.2                 | 18.6 |
|                      |                   | 5:12       | 17.8                         | 18.4 | 18.7                 | 19.2 | 19.4                 | 19.8 | 11.6                         | 8.7  | 14.4                 | 12.4 | 16.1                 | 14.8 |
|                      |                   | 7:12       | 16.6                         | 17.2 | 17.2                 | 17.7 | 17.7                 | 18.1 | 10.2                         | 7.6  | 12.4                 | 10.7 | 13.6                 | 12.6 |
|                      | 48                | 3:12       | 17.1                         | 17.6 | 18                   | 18.5 | 18.8                 | 19.3 | 12.4                         | 9    | 16.1                 | 13.7 | 18.9                 | 17.2 |
|                      |                   | 5:12       | 17.2                         | 17.8 | 18.2                 | 18.7 | 18.9                 | 19.4 | 10.4                         | 7.6  | 13.2                 | 11.2 | 15                   | 13.6 |
|                      |                   | 7:12       | 16.1                         | 16.7 | 16.8                 | 17.3 | 17.2                 | 17.7 | 9.1                          | 6.6  | 11.4                 | 9.7  | 12.7                 | 11.6 |

For SI units, 1 in. = 0.0254 m, 1 lb = 0.454 kg, 1 ft = 0.3048 m.

Notes:

- (1) Shaded areas place anchors over the maximum recommended 16 ft anchor spacing. Space anchors at 16 ft in those areas.
- (2) The table is based on Exposure C conditions for basic wind speed specified in ASCE/SEI 7. Anchors for homes located in Exposure B conditions, with mean roof heights 15 ft or less, can be installed at 150 percent of the spacing listed provided the spacing does not exceed 16 ft.
- (3) The table is based on manufactured homes with an 8 ft wall height, a 1 ft eave overhang, and a minimum average weight of 20 lb/ft<sup>2</sup>.
- (4) Ground anchors must be placed within 2 ft of the ends of the home.
- (5) Linear interpolation between I-beam spacing is permitted.

**Table 7.5.2.4.1.1(b) Maximum Ground Anchor Spacing for NFPA Wind Zone II (110 mph)**

| Anchor Strength (lb) | Pier Height (in.) | Roof Pitch | Building Width — Single Unit |      |                      |      |                      |      | Building Width — Double Unit |      |                      |      |                      |      |
|----------------------|-------------------|------------|------------------------------|------|----------------------|------|----------------------|------|------------------------------|------|----------------------|------|----------------------|------|
|                      |                   |            | 12 ft                        |      | 14 ft                |      | 16 ft                |      | 24 ft                        |      | 28 ft                |      | 32 ft                |      |
|                      |                   |            | I-Beam Spacing (in.)         |      | I-Beam Spacing (in.) |      | I-Beam Spacing (in.) |      | I-Beam Spacing (in.)         |      | I-Beam Spacing (in.) |      | I-Beam Spacing (in.) |      |
|                      |                   |            | 82.5                         | 99.5 | 82.5                 | 99.5 | 82.5                 | 99.5 | 82.5                         | 99.5 | 82.5                 | 99.5 | 82.5                 | 99.5 |
| 1500                 | 25                | 3:12       | 5.6                          | 5.7  | 5.9                  | 5.7  | 6.1                  | 5.7  | 7.3                          | 7.4  | 7.4                  | 7.4  | 7.4                  | 7.5  |
|                      |                   | 5:12       | 5.7                          | 5.8  | 5.9                  | 5.8  | 6.1                  | 5.8  | 6.7                          | 6.7  | 6.6                  | 6.6  | 6.5                  | 6.6  |
|                      |                   | 7:12       | 5.3                          | 5.4  | 5.5                  | 5.4  | 5.6                  | 5.4  | 5.9                          | 6    | 5.8                  | 5.8  | 5.6                  | 5.6  |
|                      | 33                | 3:12       | 5.4                          | 5.5  | 5.7                  | 5.5  | 5.9                  | 5.5  | 7.2                          | 7.4  | 7.3                  | 7.4  | 7.4                  | 7.4  |
|                      |                   | 5:12       | 5.5                          | 5.5  | 5.7                  | 5.5  | 5.9                  | 5.5  | 6.7                          | 6.7  | 6.6                  | 6.6  | 6.5                  | 6.6  |
|                      |                   | 7:12       | 5.1                          | 5.2  | 5.3                  | 5.2  | 5.5                  | 5.2  | 5.9                          | 6    | 5.7                  | 5.8  | 5.6                  | 5.6  |
|                      | 41                | 3:12       | 5.2                          | 5.2  | 5.5                  | 5.2  | 5.7                  | 5.2  | 7.2                          | 7.5  | 7.3                  | 7.4  | 7.3                  | 7.4  |
|                      |                   | 5:12       | 5.3                          | 5.3  | 5.5                  | 5.3  | 5.8                  | 5.3  | 6.6                          | 6.7  | 6.6                  | 6.6  | 6.5                  | 6.5  |
|                      |                   | 7:12       | 4.9                          | 5    | 5.1                  | 5    | 5.3                  | 5    | 5.9                          | 6    | 5.7                  | 5.8  | 5.6                  | 5.6  |
|                      | 48                | 3:12       | 5                            | 5.1  | 5.3                  | 5.1  | 5.5                  | 5.1  | 7.2                          | 7.5  | 7.2                  | 7.4  | 7.3                  | 7.4  |
|                      |                   | 5:12       | 5.1                          | 5.1  | 5.4                  | 5.1  | 5.6                  | 5.1  | 6.6                          | 6.8  | 6.6                  | 6.6  | 6.5                  | 6.5  |
|                      |                   | 7:12       | 4.8                          | 4.8  | 5                    | 4.8  | 5.2                  | 4.8  | 5.9                          | 6    | 5.7                  | 5.8  | 5.6                  | 5.6  |
| 2000                 | 25                | 3:12       | 7.5                          | 7.6  | 7.8                  | 7.6  | 8.1                  | 7.6  | 9.7                          | 9.9  | 9.8                  | 9.9  | 9.9                  | 10   |
|                      |                   | 5:12       | 7.6                          | 7.7  | 7.9                  | 7.7  | 8.2                  | 7.7  | 8.9                          | 9    | 8.8                  | 8.9  | 8.7                  | 8.7  |
|                      |                   | 7:12       | 7.1                          | 7.2  | 7.3                  | 7.2  | 7.5                  | 7.2  | 7.9                          | 7.9  | 7.7                  | 7.7  | 7.5                  | 7.5  |
|                      | 33                | 3:12       | 7.2                          | 7.3  | 7.6                  | 7.3  | 7.8                  | 7.3  | 9.6                          | 9.9  | 9.7                  | 9.9  | 9.9                  | 9.9  |
|                      |                   | 5:12       | 7.3                          | 7.4  | 7.7                  | 7.4  | 7.9                  | 7.4  | 8.9                          | 9    | 8.8                  | 8.8  | 8.7                  | 8.7  |
|                      |                   | 7:12       | 6.8                          | 7    | 7.1                  | 7    | 7.3                  | 7    | 7.9                          | 7.9  | 7.7                  | 7.7  | 7.4                  | 7.5  |
|                      | 41                | 3:12       | 6.9                          | 7    | 7.3                  | 7    | 7.6                  | 7    | 9.6                          | 9.9  | 9.7                  | 9.8  | 9.8                  | 9.9  |
|                      |                   | 5:12       | 7                            | 7.1  | 7.4                  | 7.1  | 7.7                  | 7.1  | 8.9                          | 9    | 8.8                  | 8.8  | 8.7                  | 8.7  |
|                      |                   | 7:12       | 6.6                          | 6.7  | 6.9                  | 6.7  | 7.1                  | 6.7  | 7.9                          | 7.9  | 7.6                  | 7.7  | 7.4                  | 7.5  |
|                      | 48                | 3:12       | 6.7                          | 6.8  | 7.1                  | 6.8  | 7.4                  | 6.8  | 9.6                          | 10   | 9.6                  | 9.8  | 9.7                  | 9.8  |
|                      |                   | 5:12       | 6.8                          | 6.9  | 7.2                  | 6.9  | 7.5                  | 6.9  | 8.8                          | 9    | 8.8                  | 8.8  | 8.7                  | 8.7  |
|                      |                   | 7:12       | 6.3                          | 6.5  | 6.7                  | 6.5  | 6.9                  | 6.5  | 7.8                          | 7.9  | 7.6                  | 7.7  | 7.4                  | 7.5  |
| 2500                 | 25                | 3:12       | 9.4                          | 9.5  | 9.8                  | 9.5  | 10.1                 | 9.5  | 12.1                         | 12.4 | 12.3                 | 12.4 | 12.4                 | 12.5 |
|                      |                   | 5:12       | 9.5                          | 9.6  | 9.9                  | 9.6  | 10.2                 | 9.6  | 11.1                         | 11.2 | 11                   | 11.1 | 10.9                 | 10.9 |
|                      |                   | 7:12       | 8.9                          | 9    | 9.2                  | 9    | 9.4                  | 9    | 9.9                          | 9.9  | 9.6                  | 9.6  | 9.3                  | 9.3  |
|                      | 33                | 3:12       | 9                            | 9.1  | 9.5                  | 9.1  | 9.8                  | 9.1  | 12.1                         | 12.4 | 12.2                 | 12.3 | 12.3                 | 12.4 |
|                      |                   | 5:12       | 9.1                          | 9.2  | 9.6                  | 9.2  | 9.9                  | 9.2  | 11.1                         | 11.2 | 11                   | 11.1 | 10.9                 | 10.9 |
|                      |                   | 7:12       | 8.6                          | 8.7  | 8.9                  | 8.7  | 9.1                  | 8.7  | 9.8                          | 9.9  | 9.6                  | 9.6  | 9.3                  | 9.3  |
|                      | 41                | 3:12       | 8.7                          | 8.7  | 9.1                  | 8.7  | 9.5                  | 8.7  | 12                           | 12.4 | 12.1                 | 12.3 | 12.2                 | 12.4 |
|                      |                   | 5:12       | 8.8                          | 8.9  | 9.2                  | 8.9  | 9.6                  | 8.9  | 11.1                         | 11.2 | 11                   | 11   | 10.9                 | 10.9 |
|                      |                   | 7:12       | 8.2                          | 8.4  | 8.6                  | 8.4  | 8.8                  | 8.4  | 9.8                          | 9.9  | 9.6                  | 9.6  | 9.3                  | 9.3  |
|                      | 48                | 3:12       | 8.4                          | 8.4  | 8.9                  | 8.4  | 9.2                  | 8.4  | 11.9                         | 12.4 | 12                   | 12.3 | 12.2                 | 12.3 |
|                      |                   | 5:12       | 8.5                          | 8.6  | 9                    | 8.6  | 9.4                  | 8.6  | 11.1                         | 11.3 | 10.9                 | 11   | 10.9                 | 10.9 |
|                      |                   | 7:12       | 7.9                          | 8.1  | 8.3                  | 8.1  | 8.6                  | 8.1  | 9.8                          | 9.9  | 9.5                  | 9.6  | 9.3                  | 9.3  |
| 3150                 | 25                | 3:12       | 11.8                         | 11.9 | 12.3                 | 11.9 | 12.7                 | 11.9 | 15.3                         | 15.6 | 15.4                 | 15.6 | 15.6                 | 15.7 |
|                      |                   | 5:12       | 12                           | 12.1 | 12.5                 | 12.1 | 12.9                 | 12.1 | 14                           | 14.2 | 13.9                 | 13.9 | 13.8                 | 13.8 |
|                      |                   | 7:12       | 11.2                         | 11.4 | 11.6                 | 11.4 | 11.8                 | 11.4 | 12.4                         | 12.5 | 12.1                 | 12.1 | 11.7                 | 11.7 |
|                      | 33                | 3:12       | 11.4                         | 11.5 | 11.9                 | 11.5 | 12.4                 | 11.5 | 15.2                         | 15.6 | 15.3                 | 15.5 | 15.5                 | 15.6 |
|                      |                   | 5:12       | 11.5                         | 11.6 | 12                   | 11.6 | 12.5                 | 11.6 | 14                           | 14.2 | 13.9                 | 13.9 | 13.7                 | 13.8 |
|                      |                   | 7:12       | 10.8                         | 11   | 11.2                 | 11   | 11.5                 | 11   | 12.4                         | 12.5 | 12.1                 | 12.1 | 11.7                 | 11.7 |
|                      | 41                | 3:12       | 10.9                         | 11   | 11.5                 | 11   | 12                   | 11   | 15.1                         | 15.7 | 15.2                 | 15.5 | 15.4                 | 15.6 |
|                      |                   | 5:12       | 11                           | 11.2 | 11.6                 | 11.2 | 12.1                 | 11.2 | 14                           | 14.2 | 13.8                 | 13.9 | 13.7                 | 13.7 |
|                      |                   | 7:12       | 10.4                         | 10.5 | 10.8                 | 10.5 | 11.1                 | 10.5 | 12.4                         | 12.5 | 12                   | 12.1 | 11.7                 | 11.7 |
|                      | 48                | 3:12       | 10.5                         | 10.6 | 11.2                 | 10.6 | 11.6                 | 10.6 | 15.1                         | 15.7 | 15.1                 | 15.4 | 15.3                 | 15.5 |
|                      |                   | 5:12       | 10.7                         | 10.8 | 11.3                 | 10.8 | 11.8                 | 10.8 | 13.9                         | 14.2 | 13.8                 | 13.9 | 13.7                 | 13.7 |
|                      |                   | 7:12       | 10                           | 10.2 | 10.5                 | 10.2 | 10.8                 | 10.2 | 12.4                         | 12.5 | 12                   | 12.1 | 11.7                 | 11.7 |

For SI units, 1 in. = 0.0254 m, 1 lb = 0.454 kg, 1 ft = 0.3048 m.

- Notes:
- (1) The table is based on Exposure C conditions for basic wind speed specified in ASCE/SEI 7. Anchors for homes located in Exposure B conditions, with mean roof heights 15 ft or less, can be installed at 150 percent of the spacing listed provided the spacing does not exceed 16 ft.
  - (2) The table is based on manufactured homes with an 8 ft wall height, a 1 ft eave overhang, and a minimum average weight of 20 lb/ft<sup>2</sup>.
  - (3) Ground anchors must be placed within 2 ft of the ends of the home.
  - (4) Linear interpolation between I-beam spacing is permitted.

Table 7.5.2.4.1.1(c) Maximum Ground Anchor Spacing for NFPA Wind Zone III (130 mph)

| Anchor Strength (lb) | Pier Height (in.) | Roof Pitch | Building Width — Single Unit |      |                      |      |                      |      | Building Width — Double Unit |      |                      |      |                      |      |
|----------------------|-------------------|------------|------------------------------|------|----------------------|------|----------------------|------|------------------------------|------|----------------------|------|----------------------|------|
|                      |                   |            | 12 ft                        |      | 14 ft                |      | 16 ft                |      | 24 ft                        |      | 28 ft                |      | 32 ft                |      |
|                      |                   |            | I-Beam Spacing (in.)         |      | I-Beam Spacing (in.) |      | I-Beam Spacing (in.) |      | I-Beam Spacing (in.)         |      | I-Beam Spacing (in.) |      | I-Beam Spacing (in.) |      |
|                      |                   |            | 82.5                         | 99.5 | 82.5                 | 99.5 | 82.5                 | 99.5 | 82.5                         | 99.5 | 82.5                 | 99.5 | 82.5                 | 99.5 |
| 1500                 | 25                | 3:12       | 3.9                          | 3.9  | 4                    | 3.9  | 4.2                  | 3.9  | 4.7                          | 4.8  | 4.7                  | 4.8  | 4.7                  | 4.7  |
|                      |                   | 5:12       | 3.9                          | 4    | 4.1                  | 4    | 4.2                  | 4    | 4.6                          | 4.6  | 4.5                  | 4.6  | 4.5                  | 4.5  |
|                      |                   | 7:12       | 3.7                          | 3.7  | 3.8                  | 3.7  | 3.9                  | 3.7  | 4.1                          | 4.2  | 4                    | 4    | 3.9                  | 3.9  |
|                      | 33                | 3:12       | 3.7                          | 3.7  | 3.9                  | 3.7  | 4                    | 3.7  | 4.7                          | 4.9  | 4.7                  | 4.7  | 4.7                  | 4.7  |
|                      |                   | 5:12       | 3.8                          | 3.8  | 4                    | 3.8  | 4.1                  | 3.8  | 4.6                          | 4.7  | 4.5                  | 4.6  | 4.5                  | 4.5  |
|                      |                   | 7:12       | 3.6                          | 3.6  | 3.7                  | 3.6  | 3.8                  | 3.6  | 4.1                          | 4.2  | 4                    | 4    | 3.9                  | 3.9  |
|                      | 41                | 3:12       | 3.6                          | 3.6  | 3.8                  | 3.6  | 3.9                  | 3.6  | 4.7                          | 4.9  | 4.7                  | 4.7  | 4.7                  | 4.7  |
|                      |                   | 5:12       | 3.6                          | 3.7  | 3.8                  | 3.7  | 4                    | 3.7  | 4.5                          | 4.7  | 4.5                  | 4.5  | 4.5                  | 4.5  |
|                      |                   | 7:12       | 3.4                          | 3.5  | 3.6                  | 3.5  | 3.7                  | 3.5  | 4.1                          | 4.2  | 4                    | 4    | 3.9                  | 3.9  |
|                      | 48                | 3:12       | 3.5                          | 3.5  | 3.6                  | 3.5  | 3.8                  | 3.5  | 4.7                          | 4.9  | 4.6                  | 4.7  | 4.6                  | 4.7  |
|                      |                   | 5:12       | 3.5                          | 3.5  | 3.7                  | 3.5  | 3.9                  | 3.5  | 4.5                          | 4.7  | 4.5                  | 4.5  | 4.4                  | 4.5  |
|                      |                   | 7:12       | 3.3                          | 3.3  | 3.5                  | 3.3  | 3.6                  | 3.3  | 4.1                          | 4.2  | 4                    | 4    | 3.9                  | 3.9  |
| 2000                 | 25                | 3:12       | 5.2                          | 5.2  | 5.4                  | 5.2  | 5.5                  | 5.2  | 6.3                          | 6.5  | 6.3                  | 6.4  | 6.3                  | 6.3  |
|                      |                   | 5:12       | 5.2                          | 5.3  | 5.5                  | 5.3  | 5.6                  | 5.3  | 6.1                          | 6.2  | 6                    | 6.1  | 6                    | 6    |
|                      |                   | 7:12       | 4.9                          | 5    | 5.1                  | 5    | 5.2                  | 5    | 5.5                          | 5.6  | 5.3                  | 5.4  | 5.2                  | 5.2  |
|                      | 33                | 3:12       | 5                            | 5    | 5.2                  | 5    | 5.4                  | 5    | 6.3                          | 6.5  | 6.3                  | 6.3  | 6.3                  | 6.3  |
|                      |                   | 5:12       | 5                            | 5.1  | 5.3                  | 5.1  | 5.5                  | 5.1  | 6.1                          | 6.2  | 6                    | 6.1  | 6                    | 6    |
|                      |                   | 7:12       | 4.7                          | 4.8  | 4.9                  | 4.8  | 5                    | 4.8  | 5.5                          | 5.6  | 5.3                  | 5.4  | 5.2                  | 5.2  |
|                      | 41                | 3:12       | 4.8                          | 4.8  | 5                    | 4.8  | 5.2                  | 4.8  | 6.3                          | 6.5  | 6.2                  | 6.3  | 6.2                  | 6.2  |
|                      |                   | 5:12       | 4.8                          | 4.9  | 5.1                  | 4.9  | 5.3                  | 4.9  | 6                            | 6.2  | 6                    | 6.1  | 5.9                  | 6    |
|                      |                   | 7:12       | 4.6                          | 4.6  | 4.7                  | 4.6  | 4.9                  | 4.6  | 5.4                          | 5.6  | 5.3                  | 5.4  | 5.2                  | 5.2  |
|                      | 48                | 3:12       | 4.6                          | 4.6  | 4.9                  | 4.6  | 5.1                  | 4.6  | 6.2                          | 6.5  | 6.2                  | 6.3  | 6.2                  | 6.2  |
|                      |                   | 5:12       | 4.7                          | 4.7  | 4.9                  | 4.7  | 5.1                  | 4.7  | 6                            | 6.2  | 6                    | 6    | 5.9                  | 6    |
|                      |                   | 7:12       | 4.4                          | 4.5  | 4.6                  | 4.5  | 4.8                  | 4.5  | 5.4                          | 5.6  | 5.3                  | 5.3  | 5.2                  | 5.2  |
| 2500                 | 25                | 3:12       | 6.5                          | 6.5  | 6.7                  | 6.5  | 6.9                  | 6.5  | 7.9                          | 8.1  | 7.9                  | 7.9  | 7.9                  | 7.9  |
|                      |                   | 5:12       | 6.6                          | 6.6  | 6.8                  | 6.6  | 7                    | 6.6  | 7.6                          | 7.7  | 7.6                  | 7.6  | 7.5                  | 7.5  |
|                      |                   | 7:12       | 6.2                          | 6.2  | 6.4                  | 6.2  | 6.5                  | 6.2  | 6.9                          | 6.9  | 6.7                  | 6.7  | 6.5                  | 6.6  |
|                      | 33                | 3:12       | 6.2                          | 6.2  | 6.5                  | 6.2  | 6.7                  | 6.2  | 7.9                          | 8.1  | 7.8                  | 7.9  | 7.8                  | 7.8  |
|                      |                   | 5:12       | 6.3                          | 6.3  | 6.6                  | 6.3  | 6.8                  | 6.3  | 7.6                          | 7.8  | 7.5                  | 7.6  | 7.5                  | 7.5  |
|                      |                   | 7:12       | 5.9                          | 6    | 6.1                  | 6    | 6.3                  | 6    | 6.8                          | 7    | 6.7                  | 6.7  | 6.5                  | 6.5  |
|                      | 41                | 3:12       | 6                            | 6    | 6.3                  | 6    | 6.5                  | 6    | 7.8                          | 8.1  | 7.8                  | 7.9  | 7.8                  | 7.8  |
|                      |                   | 5:12       | 6                            | 6.1  | 6.4                  | 6.1  | 6.6                  | 6.1  | 7.6                          | 7.8  | 7.5                  | 7.6  | 7.4                  | 7.5  |
|                      |                   | 7:12       | 5.7                          | 5.8  | 5.9                  | 5.8  | 6.1                  | 5.8  | 6.8                          | 7    | 6.6                  | 6.7  | 6.5                  | 6.5  |
|                      | 48                | 3:12       | 5.8                          | 5.8  | 6.1                  | 5.8  | 6.3                  | 5.8  | 7.8                          | 8.1  | 7.7                  | 7.8  | 7.7                  | 7.8  |
|                      |                   | 5:12       | 5.8                          | 5.9  | 6.2                  | 5.9  | 6.4                  | 5.9  | 7.5                          | 7.8  | 7.4                  | 7.5  | 7.4                  | 7.4  |
|                      |                   | 7:12       | 5.5                          | 5.6  | 5.8                  | 5.6  | 5.9                  | 5.6  | 6.8                          | 7    | 6.6                  | 6.7  | 6.5                  | 6.5  |
| 3150                 | 25                | 3:12       | 8.1                          | 8.2  | 8.5                  | 8.2  | 8.7                  | 8.2  | 10                           | 10.2 | 10                   | 10   | 9.9                  | 9.9  |
|                      |                   | 5:12       | 8.3                          | 8.3  | 8.6                  | 8.3  | 8.9                  | 8.3  | 9.6                          | 9.8  | 9.5                  | 9.6  | 9.5                  | 9.5  |
|                      |                   | 7:12       | 7.8                          | 7.9  | 8                    | 7.9  | 8.2                  | 7.9  | 8.6                          | 8.7  | 8.4                  | 8.5  | 8.2                  | 8.3  |
|                      | 33                | 3:12       | 7.8                          | 7.8  | 8.2                  | 7.8  | 8.5                  | 7.8  | 9.9                          | 10.2 | 9.9                  | 10   | 9.9                  | 9.9  |
|                      |                   | 5:12       | 7.9                          | 8    | 8.3                  | 8    | 8.6                  | 8    | 9.6                          | 9.8  | 9.5                  | 9.6  | 9.4                  | 9.4  |
|                      |                   | 7:12       | 7.5                          | 7.6  | 7.7                  | 7.6  | 7.9                  | 7.6  | 8.6                          | 8.8  | 8.4                  | 8.5  | 8.2                  | 8.2  |
|                      | 41                | 3:12       | 7.5                          | 7.5  | 7.9                  | 7.5  | 8.2                  | 7.5  | 9.8                          | 10.2 | 9.8                  | 9.9  | 9.8                  | 9.8  |
|                      |                   | 5:12       | 7.6                          | 7.7  | 8                    | 7.7  | 8.3                  | 7.7  | 9.5                          | 9.8  | 9.4                  | 9.5  | 9.4                  | 9.4  |
|                      |                   | 7:12       | 7.2                          | 7.3  | 7.5                  | 7.3  | 7.7                  | 7.3  | 8.6                          | 8.8  | 8.4                  | 8.4  | 8.2                  | 8.2  |
|                      | 48                | 3:12       | 7.3                          | 7.3  | 7.7                  | 7.3  | 8                    | 7.3  | 9.8                          | 10.2 | 9.7                  | 9.9  | 9.7                  | 9.8  |
|                      |                   | 5:12       | 7.4                          | 7.4  | 7.8                  | 7.4  | 8.1                  | 7.4  | 9.5                          | 9.8  | 9.4                  | 9.5  | 9.3                  | 9.4  |
|                      |                   | 7:12       | 6.9                          | 7    | 7.3                  | 7    | 7.5                  | 7    | 8.5                          | 8.8  | 8.3                  | 8.4  | 8.1                  | 8.2  |

For SI units, 1 in. = 0.0254 m, 1 lb = 0.454 kg, 1 ft = 0.3048 m.

Notes:

(1) The table is based on Exposure C conditions for basic wind speed specified in ASCE/SEI 7. Anchors for homes located in Exposure B conditions, with mean roof heights 15 ft or less, can be installed at 150 percent of the spacing listed provided the spacing does not exceed 16 ft.

(2) The table is based on manufactured homes with an 8 ft wall height, a 1 ft eave overhang, and a minimum average weight of 20 lb/ft<sup>2</sup>.

(3) Ground anchors must be placed within 2 ft of the ends of the home.

(4) Linear interpolation between I-beam spacing is permitted.

Table 7.5.2.4.1.1(d) Maximum Ground Anchor Spacing for NFPA Wind Zone IV (150 mph)

| Anchor Strength (lb) | Pier Height (in.) | Roof Pitch | Building Width — Single Unit |      |                      |      |                      |      | Building Width — Double Unit |      |                      |      |                      |      |     |
|----------------------|-------------------|------------|------------------------------|------|----------------------|------|----------------------|------|------------------------------|------|----------------------|------|----------------------|------|-----|
|                      |                   |            | 12 ft                        |      | 14ft                 |      | 16ft                 |      | 24 ft                        |      | 28ft                 |      | 32ft                 |      |     |
|                      |                   |            | I-Beam Spacing (in.)         |      | I-Beam Spacing (in.) |      | I-Beam Spacing (in.) |      | I-Beam Spacing (in.)         |      | I-Beam Spacing (in.) |      | I-Beam Spacing (in.) |      |     |
|                      |                   |            | 82.5                         | 99.5 | 82.5                 | 99.5 | 82.5                 | 99.5 | 82.5                         | 99.5 | 82.5                 | 99.5 | 82.5                 | 99.5 |     |
| 1500                 | 25                | 3:12       | 2.8                          | 2.8  | 2.9                  | 2.8  | 3                    | 2.8  | 3.3                          | 3.4  | 3.3                  | 3.3  | 3.3                  | 3.3  | 3.3 |
|                      |                   | 5:12       | 2.9                          | 2.9  | 3                    | 2.9  | 3.1                  | 2.9  | 3.3                          | 3.4  | 3.3                  | 3.3  | 3.2                  | 3.2  | 3.2 |
|                      |                   | 7:12       | 2.7                          | 2.7  | 2.8                  | 2.7  | 2.9                  | 2.7  | 3                            | 3    | 2.9                  | 2.9  | 2.9                  | 2.9  | 2.9 |
|                      | 33                | 3:12       | 2.7                          | 2.7  | 2.8                  | 2.7  | 2.9                  | 2.7  | 3.3                          | 3.4  | 3.3                  | 3.3  | 3.2                  | 3.2  | 3.2 |
|                      |                   | 5:12       | 2.8                          | 2.8  | 2.9                  | 2.8  | 3                    | 2.8  | 3.3                          | 3.4  | 3.2                  | 3.3  | 3.2                  | 3.2  | 3.2 |
|                      |                   | 7:12       | 2.6                          | 2.6  | 2.7                  | 2.6  | 2.8                  | 2.6  | 3                            | 3.1  | 2.9                  | 2.9  | 2.8                  | 2.8  | 2.8 |
|                      | 41                | 3:12       | 2.6                          | 2.6  | 2.8                  | 2.6  | 2.9                  | 2.6  | 3.3                          | 3.4  | 3.3                  | 3.3  | 3.2                  | 3.2  | 3.2 |
|                      |                   | 5:12       | 2.7                          | 2.7  | 2.8                  | 2.7  | 2.9                  | 2.7  | 3.3                          | 3.4  | 3.2                  | 3.3  | 3.2                  | 3.2  | 3.2 |
|                      |                   | 7:12       | 2.5                          | 2.5  | 2.6                  | 2.5  | 2.7                  | 2.5  | 3                            | 3.1  | 2.9                  | 2.9  | 2.8                  | 2.8  | 2.8 |
|                      | 48                | 3:12       | 2.5                          | 2.5  | 2.7                  | 2.5  | 2.8                  | 2.5  | 3.3                          | 3.4  | 3.2                  | 3.3  | 3.2                  | 3.2  | 3.2 |
|                      |                   | 5:12       | 2.6                          | 2.6  | 2.7                  | 2.6  | 2.8                  | 2.6  | 3.3                          | 3.4  | 3.2                  | 3.3  | 3.2                  | 3.2  | 3.2 |
|                      |                   | 7:12       | 2.4                          | 2.4  | 2.5                  | 2.4  | 2.6                  | 2.4  | 3                            | 3.1  | 2.9                  | 2.9  | 2.8                  | 2.8  | 2.8 |
| 2000                 | 25                | 3:12       | 3.8                          | 3.8  | 3.9                  | 3.8  | 4                    | 3.8  | 4.5                          | 4.5  | 4.4                  | 4.4  | 4.4                  | 4.4  | 4.4 |
|                      |                   | 5:12       | 3.8                          | 3.9  | 4                    | 3.9  | 4.1                  | 3.9  | 4.4                          | 4.5  | 4.4                  | 4.4  | 4.3                  | 4.3  | 4.3 |
|                      |                   | 7:12       | 3.6                          | 3.7  | 3.7                  | 3.7  | 3.8                  | 3.7  | 4                            | 4.1  | 3.9                  | 3.9  | 3.8                  | 3.8  | 3.8 |
|                      | 33                | 3:12       | 3.6                          | 3.6  | 3.8                  | 3.6  | 3.9                  | 3.6  | 4.4                          | 4.5  | 4.4                  | 4.4  | 4.3                  | 4.3  | 4.3 |
|                      |                   | 5:12       | 3.7                          | 3.7  | 3.9                  | 3.7  | 4                    | 3.7  | 4.4                          | 4.5  | 4.3                  | 4.4  | 4.3                  | 4.3  | 4.3 |
|                      |                   | 7:12       | 3.5                          | 3.5  | 3.6                  | 3.5  | 3.7                  | 3.5  | 4                            | 4.1  | 3.9                  | 3.9  | 3.8                  | 3.8  | 3.8 |
|                      | 41                | 3:12       | 3.5                          | 3.5  | 3.7                  | 3.5  | 3.8                  | 3.5  | 4.4                          | 4.6  | 4.3                  | 4.4  | 4.3                  | 4.3  | 4.3 |
|                      |                   | 5:12       | 3.5                          | 3.6  | 3.7                  | 3.6  | 3.9                  | 3.6  | 4.4                          | 4.5  | 4.3                  | 4.4  | 4.3                  | 4.3  | 4.3 |
|                      |                   | 7:12       | 3.3                          | 3.4  | 3.5                  | 3.4  | 3.6                  | 3.4  | 4                            | 4.1  | 3.9                  | 3.9  | 3.8                  | 3.8  | 3.8 |
|                      | 48                | 3:12       | 3.4                          | 3.4  | 3.6                  | 3.4  | 3.7                  | 3.4  | 4.4                          | 4.6  | 4.3                  | 4.4  | 4.3                  | 4.3  | 4.3 |
|                      |                   | 5:12       | 3.4                          | 3.4  | 3.6                  | 3.4  | 3.8                  | 3.4  | 4.3                          | 4.5  | 4.3                  | 4.3  | 4.2                  | 4.2  | 4.2 |
|                      |                   | 7:12       | 3.2                          | 3.3  | 3.4                  | 3.3  | 3.5                  | 3.3  | 3.9                          | 4.1  | 3.8                  | 3.9  | 3.8                  | 3.8  | 3.8 |
| 2500                 | 25                | 3:12       | 4.7                          | 4.7  | 4.9                  | 4.7  | 5.1                  | 4.7  | 5.6                          | 5.7  | 5.5                  | 5.5  | 5.5                  | 5.4  | 5.4 |
|                      |                   | 5:12       | 4.8                          | 4.8  | 5                    | 4.8  | 5.2                  | 4.8  | 5.5                          | 5.6  | 5.4                  | 5.5  | 5.4                  | 5.4  | 5.4 |
|                      |                   | 7:12       | 4.5                          | 4.6  | 4.7                  | 4.6  | 4.8                  | 4.6  | 5                            | 5.1  | 4.9                  | 4.9  | 4.8                  | 4.8  | 4.8 |
|                      | 33                | 3:12       | 4.5                          | 4.5  | 4.7                  | 4.5  | 4.9                  | 4.5  | 5.5                          | 5.7  | 5.5                  | 5.5  | 5.4                  | 5.4  | 5.4 |
|                      |                   | 5:12       | 4.6                          | 4.6  | 4.8                  | 4.6  | 5                    | 4.6  | 5.5                          | 5.6  | 5.4                  | 5.5  | 5.4                  | 5.4  | 5.4 |
|                      |                   | 7:12       | 4.4                          | 4.4  | 4.5                  | 4.4  | 4.6                  | 4.4  | 5                            | 5.1  | 4.9                  | 4.9  | 4.7                  | 4.7  | 4.7 |
|                      | 41                | 3:12       | 4.4                          | 4.4  | 4.6                  | 4.4  | 4.8                  | 4.4  | 5.5                          | 5.7  | 5.4                  | 5.5  | 5.4                  | 5.4  | 5.4 |
|                      |                   | 5:12       | 4.4                          | 4.5  | 4.7                  | 4.5  | 4.8                  | 4.5  | 5.4                          | 5.6  | 5.4                  | 5.4  | 5.3                  | 5.3  | 5.3 |
|                      |                   | 7:12       | 4.2                          | 4.2  | 4.4                  | 4.2  | 4.5                  | 4.2  | 5                            | 5.1  | 4.8                  | 4.9  | 4.7                  | 4.7  | 4.7 |
|                      | 48                | 3:12       | 4.2                          | 4.2  | 4.4                  | 4.2  | 4.6                  | 4.2  | 5.5                          | 5.7  | 5.4                  | 5.5  | 5.3                  | 5.3  | 5.3 |
|                      |                   | 5:12       | 4.3                          | 4.3  | 4.5                  | 4.3  | 4.7                  | 4.3  | 5.4                          | 5.6  | 5.3                  | 5.4  | 5.3                  | 5.3  | 5.3 |
|                      |                   | 7:12       | 4                            | 4.1  | 4.2                  | 4.1  | 4.4                  | 4.1  | 4.9                          | 5.1  | 4.8                  | 4.9  | 4.7                  | 4.7  | 4.7 |
| 3150                 | 25                | 3:12       | 6                            | 6    | 6.2                  | 6    | 6.4                  | 6    | 7                            | 7.1  | 6.9                  | 7    | 6.9                  | 6.9  | 6.9 |
|                      |                   | 5:12       | 6.1                          | 6.1  | 6.3                  | 6.1  | 6.5                  | 6.1  | 6.9                          | 7.1  | 6.9                  | 6.9  | 6.8                  | 6.8  | 6.8 |
|                      |                   | 7:12       | 5.7                          | 5.8  | 5.9                  | 5.8  | 6                    | 5.8  | 6.3                          | 6.4  | 6.1                  | 6.2  | 6                    | 6    | 6   |
|                      | 33                | 3:12       | 5.7                          | 5.7  | 6                    | 5.7  | 6.2                  | 5.7  | 7                            | 7.2  | 6.9                  | 6.9  | 6.8                  | 6.8  | 6.8 |
|                      |                   | 5:12       | 5.8                          | 5.8  | 6.1                  | 5.8  | 6.3                  | 5.8  | 6.9                          | 7.1  | 6.8                  | 6.9  | 6.8                  | 6.8  | 6.8 |
|                      |                   | 7:12       | 5.5                          | 5.5  | 5.7                  | 5.5  | 5.8                  | 5.5  | 6.3                          | 6.4  | 6.1                  | 6.2  | 6                    | 6    | 6   |
|                      | 41                | 3:12       | 5.5                          | 5.5  | 5.8                  | 5.5  | 6                    | 5.5  | 6.9                          | 7.2  | 6.8                  | 6.9  | 6.8                  | 6.8  | 6.8 |
|                      |                   | 5:12       | 5.6                          | 5.6  | 5.9                  | 5.6  | 6.1                  | 5.6  | 6.9                          | 7.1  | 6.8                  | 6.9  | 6.7                  | 6.7  | 6.7 |
|                      |                   | 7:12       | 5.3                          | 5.3  | 5.5                  | 5.3  | 5.7                  | 5.3  | 6.2                          | 6.4  | 6.1                  | 6.2  | 5.9                  | 5.9  | 5.9 |
|                      | 48                | 3:12       | 5.3                          | 5.3  | 5.6                  | 5.3  | 5.8                  | 5.3  | 6.9                          | 7.2  | 6.8                  | 6.9  | 6.7                  | 6.7  | 6.7 |
|                      |                   | 5:12       | 5.4                          | 5.4  | 5.7                  | 5.4  | 5.9                  | 5.4  | 6.8                          | 7.1  | 6.7                  | 6.8  | 6.7                  | 6.7  | 6.7 |
|                      |                   | 7:12       | 5.1                          | 5.1  | 5.3                  | 5.1  | 5.5                  | 5.1  | 6.2                          | 6.4  | 6.1                  | 6.1  | 5.9                  | 5.9  | 5.9 |

For SI units, 1 in. = 0.0254 m, 1 lb = 0.454 kg, 1 ft = 0.3048 m.

Notes:

(1) Shaded areas show spacing is less than 2 ft 8 in. Closely spaced ground anchors can fall within the soil interaction zone for adjacent ground anchors. For ground anchors spacing less than 2 ft 8 in., install alternate support and anchorage system unless the ground anchor manufacturer certifies the ground anchors for the designated spacing.

(2) The table is based on Exposure C conditions for basic wind speed specified in ASCE/SEI 7. Anchors for homes located in Exposure B conditions, with mean roof heights 15 ft or less, can be installed at 150 percent of the spacing listed provided the spacing does not exceed 16 ft.

(3) The table is based on manufactured homes with an 8 ft wall height, a 1 ft eave overhang, and a minimum average weight of 20 lb/ft<sup>2</sup>.

(4) Ground anchors must be placed within 2 ft of the ends of the home.

(5) Linear interpolation between I-beam spacing is permitted.

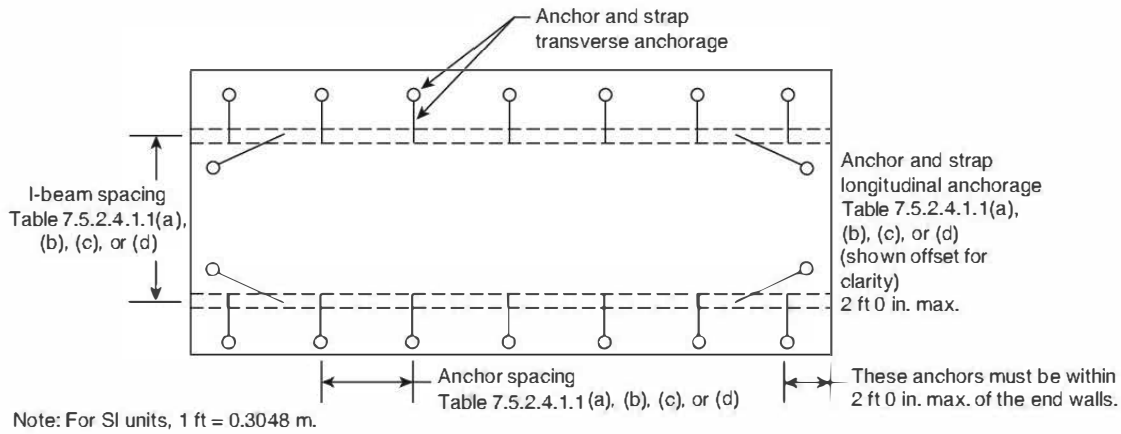

FIGURE 7.5.2.4.1.1(a) Anchor Spacing and Location.

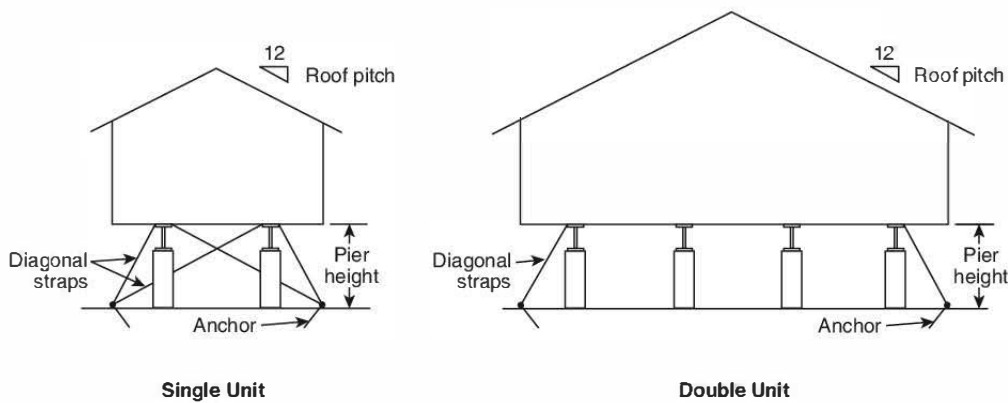

FIGURE 7.5.2.4.1.1(b) Anchor Position Using Diagonal Straps.

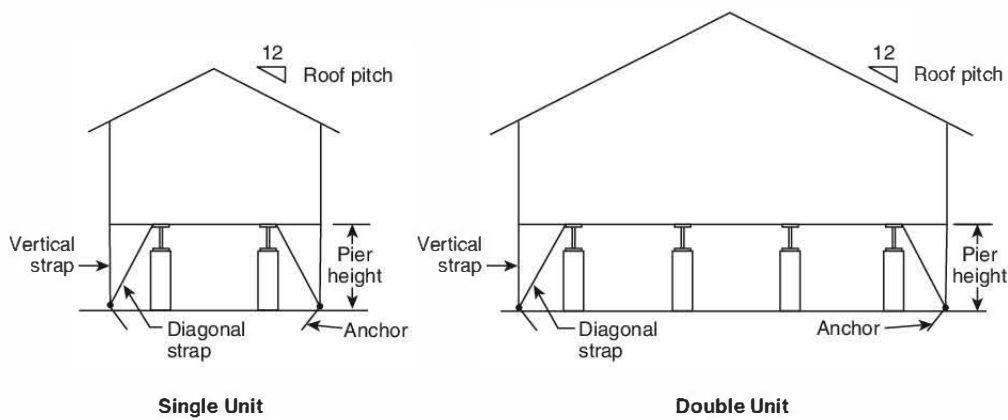

FIGURE 7.5.2.4.1.1(c) Anchor Position Using Diagonal and Vertical Straps.

**Table 7.5.2.4.2.2 Longitudinal Anchorage — Number of Anchors Per Building End**

| Wind Zone<br>(Speed)  | Anchor<br>Strength | Building Width — Single Unit |       |       | Building Width — Double Unit |       |       |
|-----------------------|--------------------|------------------------------|-------|-------|------------------------------|-------|-------|
|                       |                    | 12 ft                        | 14 ft | 16 ft | 24 ft                        | 28 ft | 32 ft |
| NFPA I<br>(90 mph)    | 1500               | 2                            | 2     | 2     | 3                            | 4     | 4     |
|                       | 2000               | 2                            | 2     | 2     | 3                            | 3     | 4     |
|                       | 2500               | 1                            | 2     | 2     | 2                            | 3     | 3     |
|                       | 3150               | 1                            | 1     | 1     | 2                            | 2     | 2     |
| NFPA II<br>(110 mph)  | 1500               | 3                            | 3     | 3     | 5                            | 6     | 6     |
|                       | 2000               | 2                            | 2     | 3     | 4                            | 4     | 4     |
|                       | 2500               | 2                            | 2     | 2     | 3                            | 4     | 4     |
|                       | 3150               | 2                            | 2     | 2     | 3                            | 3     | 3     |
| NFPA III<br>(130 mph) | 1500               | 4                            | 4     | 4     | 7                            | 7     | 7     |
|                       | 2000               | 3                            | 3     | 4     | 5                            | 6     | 7     |
|                       | 2500               | 2                            | 3     | 3     | 4                            | 5     | 5     |
|                       | 3150               | 2                            | 2     | 2     | 3                            | 4     | 4     |
| NFPA IV<br>(150 mph)  | 1500               | 5                            | 5     | 6     | 9                            | 10    | 12    |
|                       | 2000               | 4                            | 4     | 5     | 7                            | 8     | 9     |
|                       | 2500               | 3                            | 3     | 4     | 6                            | 6     | 7     |
|                       | 3150               | 2                            | 3     | 3     | 4                            | 5     | 6     |

**7.5.4.2\* Severe Wind Zones.**

**7.5.4.2.1** Before a home is installed within 1500 ft (457 m) of a coastline in Wind Zones II or III, the manufacturer's installation instructions shall be used.

**7.5.4.2.2** When the manufacturer's installation instructions are not available, the design shall be by a registered professional engineer.

**7.5.4.3 Flood Hazard Areas.** See Chapter 12.

**7.6 Installation of On-Site Structures.**

**7.6.1** All buildings and structures shall be designed to support all of their own live and dead loads.

**7.6.2** Fire separation distance shall be provided, as the AHJ requires, for occupancy.

**7.6.3 Expanding Rooms.**

**7.6.3.1** Expanding rooms shall be installed in accordance with the manufacturer's instructions.

**7.6.3.2** When the manufacturer's instructions are not available, perimeter blocking shall be installed in accordance with Table 6.2.3.1.2(a), and anchors shall be installed in accordance with 7.5.2.4.

**7.6.4 Garages and Carports.**

**7.6.4.1** A garage or carport shall be installed in accordance with the manufacturer's instructions, in accordance with a design by a registered professional engineer, or in accordance with the requirements of the AHJ.

**7.6.4.2** The garage or carport shall be supported independently of the factory-built portion of the manufactured home or in accordance with the manufacturer's installation instructions.

**7.6.4.3** Electrical circuits in a garage shall be provided with ground-fault circuit protection.

**7.6.5 Porches.** Site-constructed porches shall be constructed and inspected according to applicable building codes.

**7.6.6 Steps, Stairways, and Landings.** Steps, stairways, and landings shall be constructed and inspected according to applicable building codes.

**7.7 Installation Close-Up/Finishing.****7.7.1 Single and Multisection Exterior and Interior Close-Up.**

**7.7.1.1\*** Prior to installing the siding, the polyethylene sheeting covering exterior walls in transit shall be completely removed.

**7.7.1.2** Holes in the roof made in transit or setup shall be sealed with exterior sealant.

**7.7.1.3** Mating line (sealer) gaskets shall be installed according to Figure 7.7.1.3. Sealer gasket materials shall conform to the manufacturer's installation instructions or shall be permitted to consist of aerosol dispensed polyurethane foams to form a tight seal when the manufactured home floor sections are positioned together. Carpet pads or fiberglass insulation products shall not be used as sealer gasket materials.

**7.7.2\* Exterior Siding Close-Up.**

**7.7.2.1** Exterior siding shall be installed according to the siding manufacturer's installation instructions.

**7.7.2.2** Exterior close-up strips/trim shall be fastened securely and sealed with exterior sealant.

**7.7.3 Interior Close-Up.**

**7.7.3.1** All shipping blocking, strapping, or bracing shall be removed from appliances, windows, and doors.

**7.7.3.2** All loose items packaged or shipped with the home shall be installed.

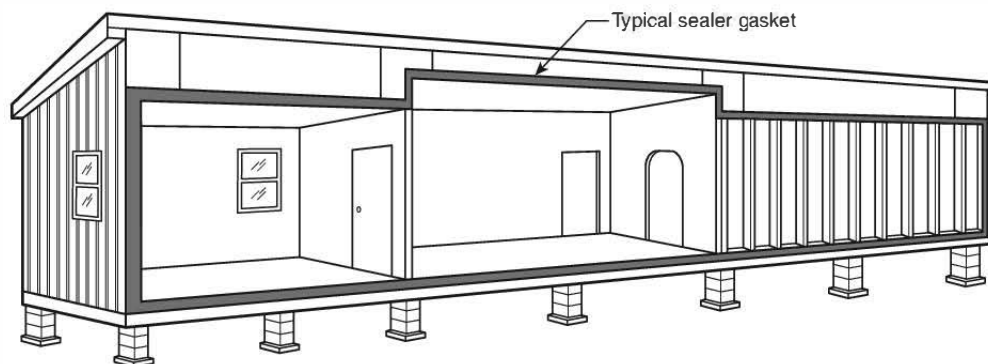

Note: On multisection manufactured homes, install sealer gasket on the ceiling, end walls, and floor mating line prior to joining the sections together.

**FIGURE 7.7.1.3 Typical Sealer Gasket Installation.**

**7.7.3.3** All ship loose wall paneling shall be installed using a  $\frac{1}{4}$  in. (6.3 mm) bead of polyvinyl acetate (PVA) adhesive on all framing members.

**7.7.3.4** Panels shall be fastened with minimum 1 in. (25 mm) long staples or nails at 6 in. (150 mm) on center panel edges and 12 in. (305 mm) on center in the field.

#### **7.7.4 Unfinished Gypsum Wallboard.**

**7.7.4.1** Homes shipped with unfinished gypsum wallboard and/or ceiling shall be finished on site.

##### **7.7.4.2\* Bottom Board Repair.**

**7.7.4.2.1** The bottom board covering shall be inspected for any loosening or areas that might have been damaged or torn during installation or transportation.

**7.7.4.2.2** Any splits, tears, or openings in the bottom covering shall be resealed with approved tape or patches specifically designed for repairs of the bottom covering.

**7.7.4.2.3** Plumbing P-traps shall be checked to be sure they are well insulated and covered.

**7.7.4.2.4** All edges of patches shall be taped.

#### **7.7.5 Interior Finish.**

**7.7.5.1** The interior finishes shall have the following maximum flame spread index values measured in accordance with ASTM E84, *Standard Test Method for Surface Burning Characteristics of Building Materials*, or with UL 723, *Test for Surface Burning Characteristics of Building Materials*.

- (1) Ceilings — 75
- (2) Walls — 75
- (3) General — 200
- (4) Adjacent to cooking range — 50
- (5) Adjacent to or enclosing a furnace or water heater — 25

**7.7.5.2** Interior finishes that have been tested to NFPA 286 and that comply with the following criteria shall be acceptable for use as required by 7.7.5.1:

- (1) During the 40 kW exposure, flames shall not spread to the ceiling.
- (2) The flame shall not spread to the outer extremity of the sample on any wall or ceiling.

- (3) Flashover, as described in NFPA 286, shall not occur.
- (4) The peak heat release rate throughout the test shall not exceed 800 kW.

## **Chapter 8 Site-Installed Features**

**8.1 Installation of Site-Installed Features.** Where applicable and specific to the manufacturer's product, optional features shall be permitted to be installed.

**8.1.1** Carports, awnings, porches, roof covers, and other structural attachments or additions shall not be connected to or supported by a manufactured home unless the home was specifically designed to accommodate such attachments.

**8.1.2** Structure or attachments added to a manufactured home shall be designed per NFPA 5000, Chapter 35, and shall be structurally independent of the manufactured home.

**8.1.2.1** Connections between added structures and attachments and the manufactured home shall be limited to those required for weathertight integrity.

**8.1.2.2** Structures and attachments added to a manufactured home shall be allowed to deflect as specified in 35.1.2.8 of NFPA 5000 without damaging the manufactured home.

#### **8.2\* Hinged Roofs and Eaves.**

**8.2.1** The manufacturer's installation instructions shall be consulted when erecting and securing in place hinged roofs or hinged eaves.

**8.2.2** Site installations of vent stacks, including furnaces, water heaters, plumbing stacks, fireplaces, and powered exhaust fans, shall conform with the manufacturer's installation instructions.

**8.3 Garden and Bay Windows.** Shipped-loose items, such as garden or bay windows, shall be installed in accordance with the manufacturer's installation instructions.

**8.4 Awnings and Ramadas.** Only freestanding products with support columns shall be chosen.

#### **8.5 Miscellaneous Lights and Fixtures.**

**8.5.1** Exterior lighting fixtures, ceiling-suspended (paddle) fans, and chain-hung lighting fixtures shall be permitted to be installed when the home is delivered.



## 8.5.2 Grounding Fixtures.

**8.5.2.1** All of the installed exterior lighting fixtures and ceiling fans per 8.5.1 shall be grounded by a fixture-grounding screw or by a fixture-grounding wire.

**8.5.2.2** For chain-hung lighting fixtures, as shown in Figure 8.5.2.2, both a fixture-grounding screw and a fixture-grounding wire shall be used.

**8.5.3** Where lighting fixtures are mounted on combustible surfaces such as hardboard, a noncombustible ring, as shown in Figure 8.5.3, shall be installed to completely cover the combustible surface exposed between the fixture canopy and the wiring outlet box.

## 8.5.4 Siding.

**8.5.4.1** If siding has not been installed at a lighting fixture location, the outlet box shall be removed, and the siding shall be installed with a hole for the outlet box.

**8.5.4.2** The outlet box shall be reinstalled and the same process followed as for other lighting fixtures, which shall be installed according to their listings.

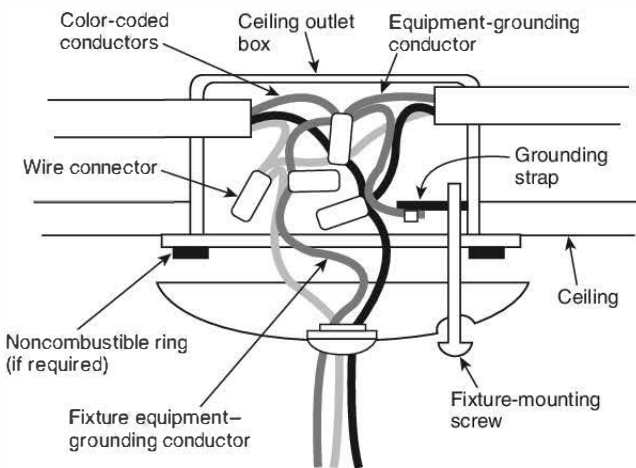

**FIGURE 8.5.2.2** Installation of Chain-Hung Lighting Fixture.

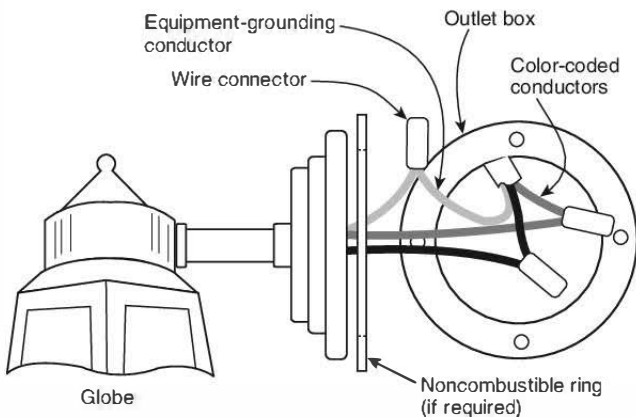

**FIGURE 8.5.3** Installation of Surface-Mounted Exterior Lighting Fixture.

## 8.5.5 Exterior Lights.

**8.5.5.1** The junction box covers shall be removed, and wire-to-wire connections shall be made using wire connectors.

**8.5.5.2** General practice shall be to connect wires black-to-black, white-to-white, and equipment ground-to-equipment ground.

**8.5.5.3** The wires shall be pushed into the box, and the lighting fixture shall be secured to the junction box.

**8.5.5.4** The lighting fixture shall be caulked around its base to ensure a watertight seal to the side wall.

**8.5.5.5** The light bulb shall be installed, and the globe shall be attached.

## 8.5.6 Ceiling Fans.

**8.5.6.1** To reduce the risk of injury, ceiling suspended (paddle) fans shall be installed with the trailing edges of the blades at least 6 ft 4 in. (1930 mm) above the floor.

**8.5.6.2** The wiring shall be connected as shown in Figure 8.5.6.2(a) and Figure 8.5.6.2(b), and the manufacturer's instructions shall be followed.

**8.5.6.3** Electrical boxes listed for the application and the weight of the fan to be supported shall be installed where the box is used as the sole support of a ceiling-suspended (paddle) fan.

**8.6\* Ventilation Options.** The component manufacturer's instructions shall be followed.

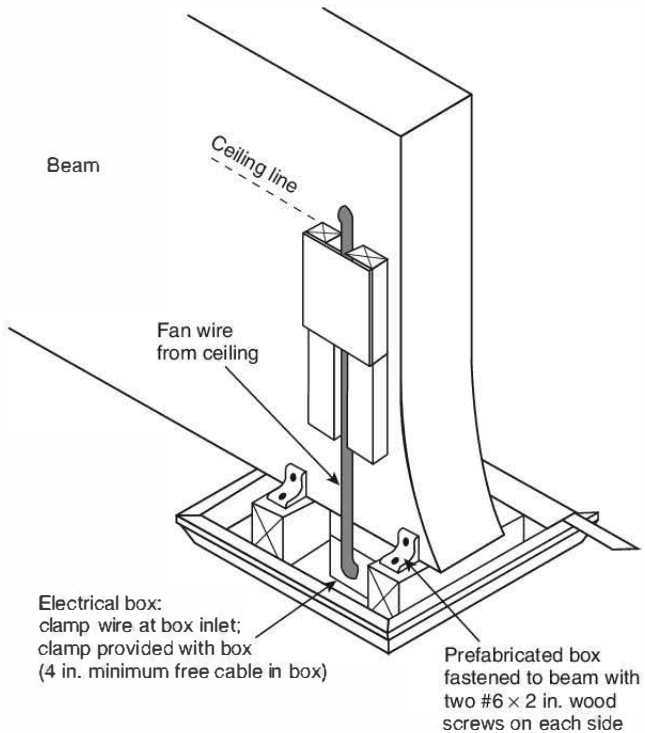

Note: For SI units, 1 in. = 25.4 mm.

**FIGURE 8.5.6.2(a)** Electrical Outlet Box and Support Structure for Ceiling-Suspended (Paddle) Fan.



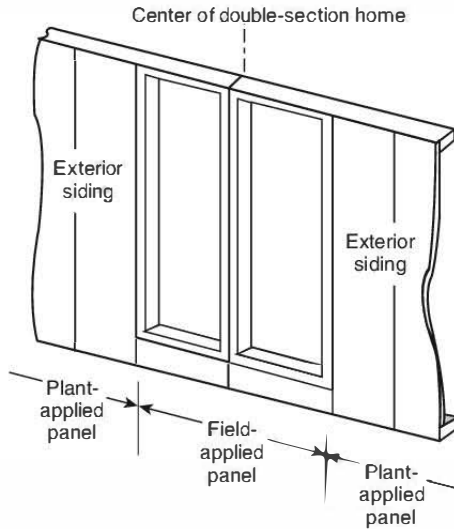

## Notes:

- (1) One full-sized panel no less than 16 in. (406.4 mm) nor larger than 32 in. (812.8 mm)
- (2) Fasten exterior panel to the studs in accordance with the siding manufacturer's installation instructions.

**FIGURE 8.7(b) Installation of Field-Applied Wood Siding at End Wall.**

**8.8.2.2** Ventilation openings shall be placed at or near each corner of the home and as high as practicable.

**8.8.2.3** Openings shall be located on at least two opposite sides to provide cross-ventilation.

**8.8.3** Access opening(s) not less than 18 in. (455 mm) in any dimension and not less than 3 ft<sup>2</sup> (0.28 m<sup>2</sup>) in area shall be provided and shall be located so that any water supply and sewer drain connections located under the home are accessible for inspections.

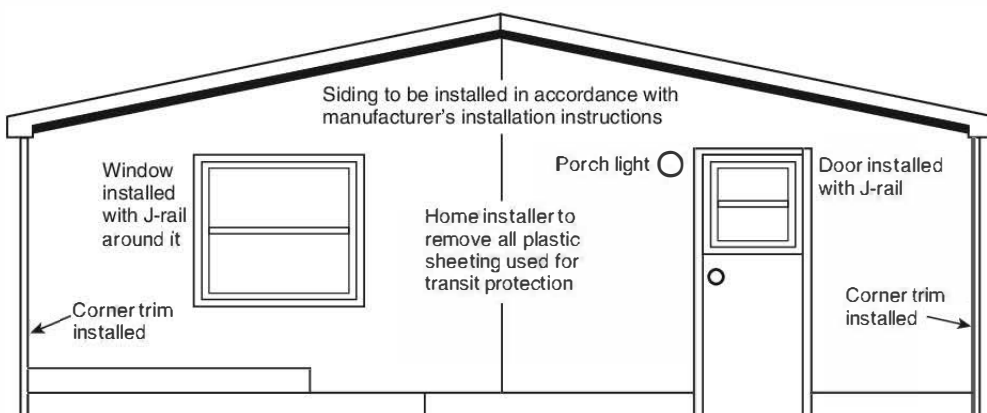

## Notes:

- (1) Double-section homes with horizontal-lap siding can be shipped with no siding on the front and rear end walls.
- (2) The manufacturer will install doors/windows trimmed with J-rail and corner trim and will cover with plastic sheeting for transit. All siding, starter trim, fasteners, and vents will be shipped loose in the home for installation on setup.
- (3) Home installer to complete installation after home is set up, including the installation of roof vents if required.

**FIGURE 8.7(c) Installation of Field-Applied Horizontal Lap Siding.**

**8.8.4** Dryer vents, air-conditioning condensation drains, and combustion air inlets shall pass through the skirting to the outside.

**8.9\*** Telephone and Cable TV. Telephone and cable TV wiring shall be installed in accordance with acceptable wiring practices.

**8.10** Joints and Seams. Where appropriate, all joints and seams that were disturbed during relocation of the home shall be made weatherproof.

## Chapter 9 Preparation of Appliances

**9.1\*** Clothes Dryer Vent. When installed, the clothes dryer shall exhaust to the exterior of the home, beyond any perimeter skirting installed around it, as shown in Figure 9.1. Transition or flexible ducts shall only be used in nonconcealed spaces and to transition from the appliance to the duct system.

**9.2\*** Comfort Cooling Systems. Comfort cooling systems shall be installed according to the manufacturer's installation instructions and applicable regulations of the AHJ.

### 9.2.1 Air Conditioners.

**9.2.1.1\*** An installed central air-conditioning system shall not exceed the rating shown on the home's compliance certificate.

**9.2.1.2\*** Circuit Rating. If a manufactured home is factory provided with an exterior outlet to energize heating and/or air-conditioning equipment, the branch circuit rating on the tag adjacent to this outlet shall be equal to or greater than the minimum circuit ampacity identified on the equipment rating plate.

### 9.2.1.3 A-Coil Units.

**9.2.1.3.1** A-coil air-conditioning units shall be compatible and listed for use with the furnace in the home.

**9.2.1.3.2** The air conditioner manufacturer's instructions shall be followed.

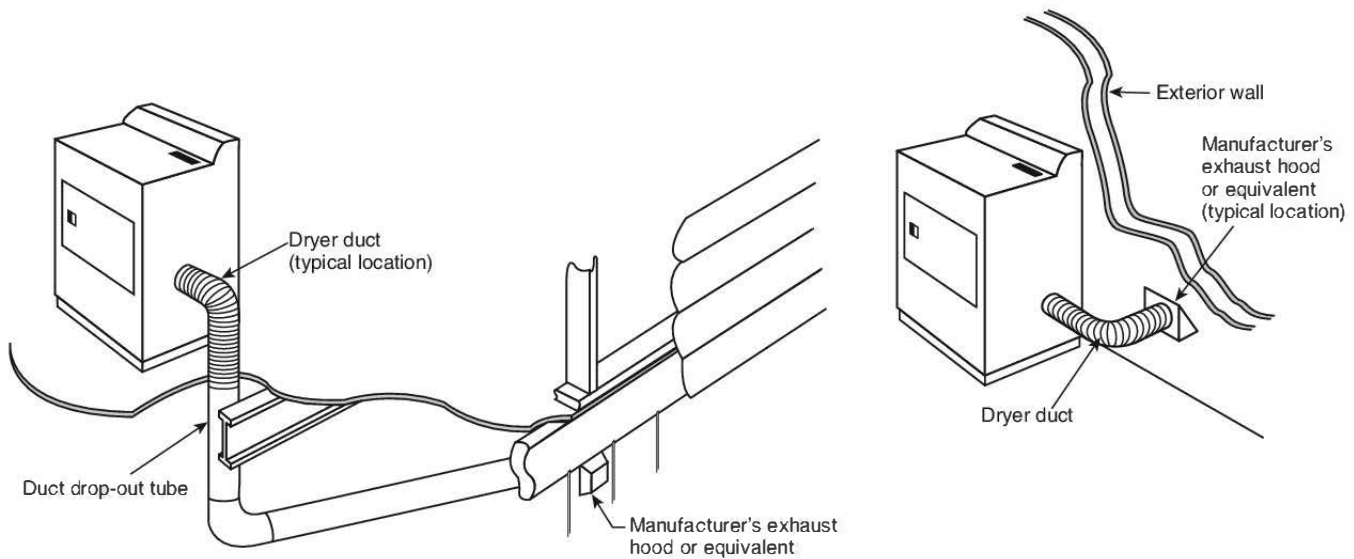

Notes:

- (1) Installation of the exhaust system must be in accordance with the dryer manufacturer's instructions.
- (2) Dryer exhaust system must not terminate under the home.

**FIGURE 9.1 Dryer Exhaust System.**

**9.2.1.3.3** All condensation shall be directed beyond the perimeter of the home by means specified by the equipment manufacturer.

**9.2.2 Heat Pumps.** Heat pumps shall be installed according to the heat pump manufacturer's instructions.

**9.2.3 Evaporative Coolers.**

**9.2.3.1** A roof-mounted cooler shall be installed in accordance with the appliance manufacturer's instructions. The discharge grille shall not be closer than 3 ft (1 m) from a smoke alarm.

**9.2.3.2** Before installing a roof-mounted cooler, the person installing the cooler shall ensure that the roof will support the weight of the cooler.

**9.2.3.3** A rigid base shall be provided to evenly distribute the cooler's weight over several rafters.

**9.3 Fireplace and Wood-Stove Chimneys and Air Inlets.**

**9.3.1** Fireplaces and wood stoves shall be permitted to require on-site installation of additional section(s) of approved, listed chimney pipe, a spark arrester, and a rain-cap assembly.

**9.3.2** Fireplace and wood-stove chimneys and air inlets shall be installed in accordance with their listings and Figure 9.3.2.

**9.3.3** All fireplaces and wood stoves installed shall be listed for use in manufactured housing.

**9.3.4** For field installation, approval from the manufacturer and the authority having jurisdiction shall be required to ensure compliance with the required standards.

**9.3.5\* Minimum Extensions Above Roof.** The finished chimney shall extend at least 3 ft (915 mm) above the highest point at which it penetrates the roof and at least 2 ft (610 mm) higher than any building or other obstruction located within a horizontal distance of 10 ft (3050 mm).

**9.3.6 Required Components.** The required components of a correctly installed chimney shall be as shown in Figure 9.3.2.

**9.3.7\* Combustion Air Duct Inlets.**

**9.3.7.1** Combustion air intake ducts shall end just below the bottom covering of the floor.

**9.3.7.2** The ducts shall be extended to the outside when the home has a basement or crawl space.

**9.3.7.3** The air intake ducts shall not be installed in a garage.

**9.3.7.4** The combustion air inlet shall not be allowed to drop material from the hearth to the area beneath the home.

**9.3.7.5** The inlet damper shall be located above the expected snow level, as shown in Figure 9.3.2.

**9.4 Range, Cooktop, and Oven Venting.**

**9.4.1** If the home is equipped with a combination range (cooktop)/grill or oven that contains its own exhaust system, the vent shall exhaust to the exterior of the home.

**9.4.2** When the vent exhausts through the floor and if perimeter skirting is installed, the vent shall extend through the exterior perimeter of the home.

**9.5 Flood Hazard Areas.** See Chapter 12.

**9.6 Seismic Design Categories D<sub>0</sub>, D<sub>1</sub>, D<sub>2</sub>, and E.** Manufactured homes located in seismic design categories D<sub>0</sub>, D<sub>1</sub>, D<sub>2</sub>, and E shall conform to the additional installation and equipment bracing requirements of 4.5.3.4.

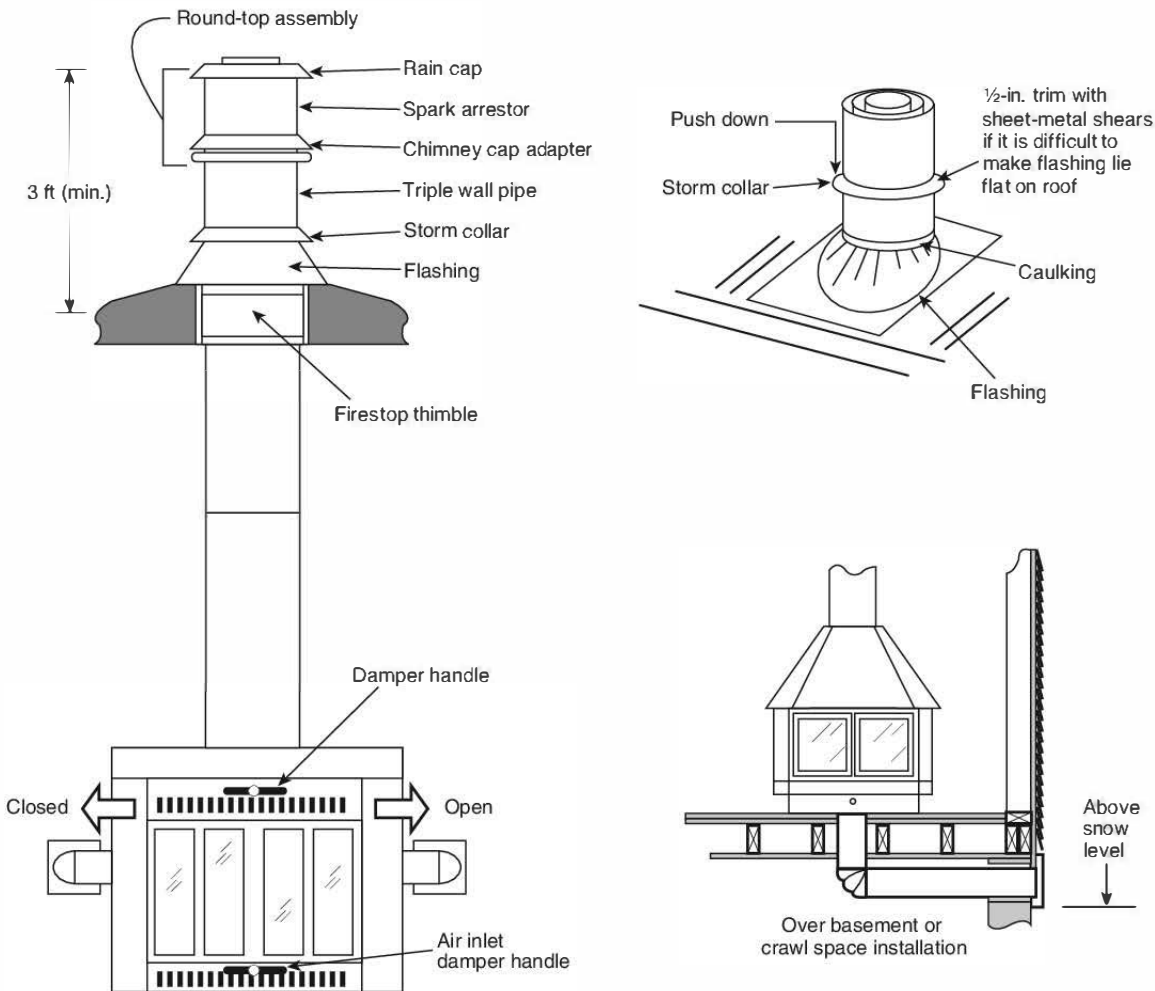

Note: For SI units, 1 in. = 25.4 mm, 1 ft = 0.3048 m.

**FIGURE 9.3.2** Installation of Fireplace or Wood Stove Chimney.

## Chapter 10 Utility System Connection and Testing

### 10.1 Proper Procedures.

**10.1.1** The authority having jurisdiction shall be consulted before connecting the manufactured home to any utilities.

**10.1.2** Where required, only qualified personnel familiar with local codes shall be permitted to make utility site connections and conduct tests at the manufactured home site.

**10.1.3** In flood hazard areas, see Chapter 12.

### 10.2 Water Supply.

**10.2.1 Maximum Supply Pressure and Reduction.** When the local water supply pressure exceeds 80 psi (0.6 MPa) to the manufactured home, a pressure-reducing valve, acceptable to the AHJ, of a bypass type shall be installed.

### 10.2.2 Connection Procedures.

#### 10.2.2.1 Mandatory Shutoff Valve.

**10.2.2.1.1** An accessible shutoff valve shall be installed between the water supply and the inlet, in a manner acceptable to the AHJ, as shown in Figure 10.2.2.1.1.

**10.2.2.1.2** The water riser for the shutoff valve connection shall be permitted to be located underneath or adjacent to the home.

**10.2.2.1.3** The shutoff valve shall be a full-flow gate or ball valve or a valve acceptable to the AHJ.

#### 10.2.2.2 Crossovers.

**10.2.2.2.1** Multisection homes with plumbing in both sections shall require water-line crossover connections, as shown in Figure 10.2.2.2.1.

**10.2.2.2.2** The shipping caps shall be removed from the water lines, and the crossover connectors provided with the home shall be installed.

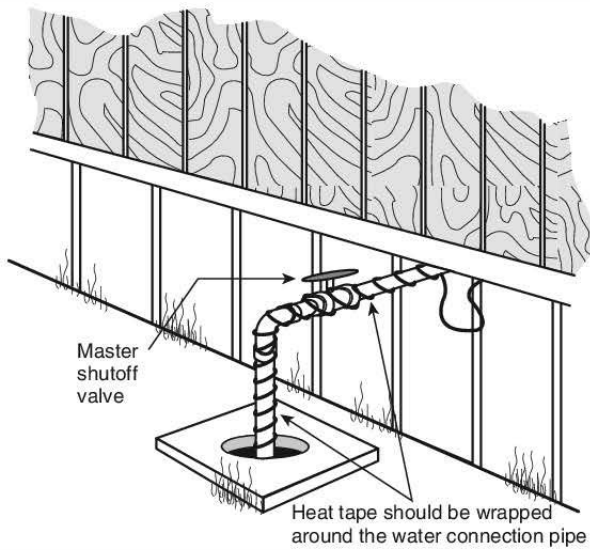

FIGURE 10.2.2.1.1 Typical Water Connection.

10.2.2.2.3 If freezing could occur, the water connectors shall be wrapped with insulation.

10.2.3 Freezing Protection.

10.2.3.1 Necessity. In areas subjected to subfreezing temperatures, exposed sections of water supply piping, shutoff valves, pressure reducers, and pipes in water heater compartments with uninsulated doors shall be protected from freezing using a method acceptable to the AHJ.

10.2.3.2\* Use of Pipe Heating Cable. Only pipe heating cable listed for manufactured home use shall be permitted to be used and shall be installed in accordance with the manufacturer's installation instructions.

10.2.4 Testing Procedures.

10.2.4.1 The water system shall be rechecked for leaks at the installation site.

10.2.4.2 The test shall be made by subjecting the system to air or water at 100 psi (0.7 MPa) for 15 minutes without loss of pressure.

10.2.5 Fire Sprinkler Systems. Fire sprinkler systems, if provided, shall have a water supply system that complies with NFPA 13D.

10.3 Drainage System.

10.3.1 Assembly and Support. If portions of the drainage system were shipped loose, they shall be reinstalled in accordance with the manufacturer's installation instructions. (See Figure 10.3.1.)

10.3.2 Proper Slopes. Drains shall be installed in accordance with 10.3.2.1 or 10.3.2.2.

10.3.2.1 Drain lines shall slope at least 1/4 in./ft (19.7 mm/m) unless otherwise noted on the schematic diagram, as shown in Figure 10.3.2.1, or in a manner acceptable to the AHJ.

10.3.2.2 A 1/8 in./ft (9.8 mm/m) fall per foot shall be permitted when a clean-out is installed at the upper end of the run.

10.3.3 Connector Sizes. The main drain line shall be connected to the site's sewer hookup, using an approved elastomer coupler, as shown in Figure 10.3.3, or in a manner acceptable to the AHJ.

10.3.4 Crossovers. Drainage line crossovers in multisection homes shall be connected in accordance with the manufacturer's installation instructions.

10.3.5 Testing Procedures.

10.3.5.1 The drainage system shall be rechecked for leaks after installation at the site.

10.3.5.2 This test shall be accomplished by capping the drain line, filling it with water, and holding it 15 minutes.

10.4 Gas Supply.

10.4.1 Conversion of Gas Appliances. A service person acceptable to the AHJ shall convert the appliance from one type of gas to another, following the instructions provided by the manufacturer of each appliance.

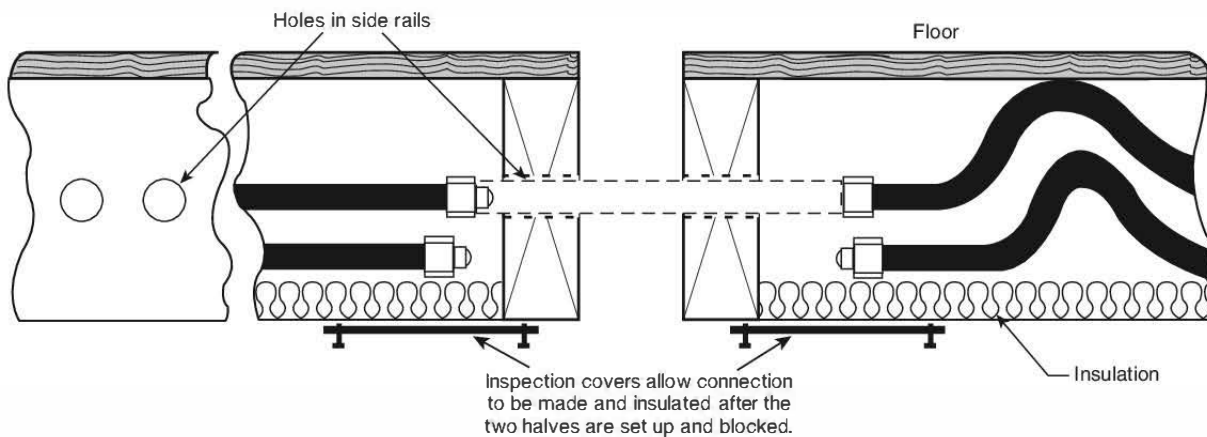

Note: If freezing conditions exist, wrap water connector with insulation. Use water connectors supplied by manufacturer, where applicable.

FIGURE 10.2.2.2.1 Typical Water-Line Crossover Connection.

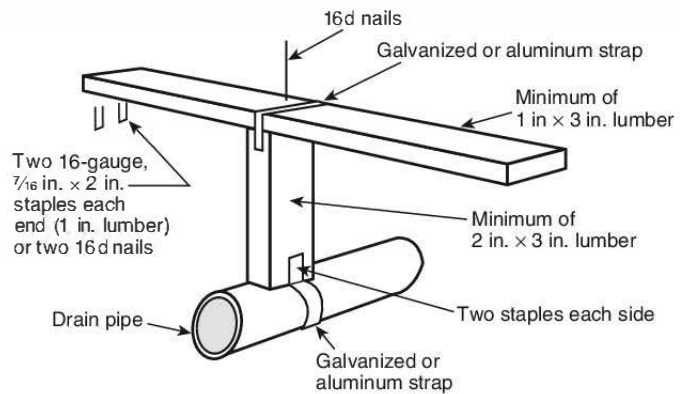
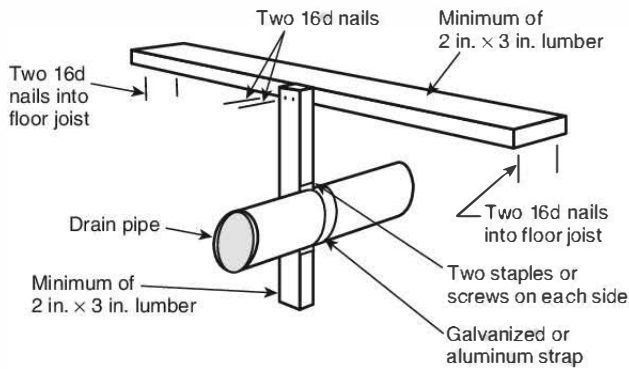

Note: For SI units, 1 in. = 25.4 mm.

**FIGURE 10.3.1 Drain Pipe Installation.**

**10.4.2\* Orifices and Regulators.** Before making any connections to the site supply, the inlet orifices of all gas-burning appliances shall be checked to ensure they are correctly set up for the type of gas to be supplied.

**10.4.3\* Proper Supply Pressure.** The gas piping system in the home shall have been designed for a pressure that is at least 10 in. of water column [5.8 oz or 0.36 psi (2.54 kPa)] and not more than 14 in. of water column [8 oz or 0.5 psi (3.5 kPa)]. If gas from any supply source exceeds, or could exceed, this pressure, a regulator shall be required to be installed.

**10.4.4\* Crossovers.**

**10.4.4.1** All crossovers and fittings shall be listed for exterior use and be of the same size as the main unit pipe.

**10.4.4.2** Tools shall not be used to connect or remove the flexible connector quick-disconnect.

**10.4.5 Testing Procedures.** The gas system shall be retested for leaks at the installation site by personnel acceptable to the AHJ (see 10.4.3).

**10.4.6\* Connection Procedures.** Gas burning-appliance vents shall be inspected to ensure that they have been connected to the appliance and that roof jacks are installed and have not come loose during transit.

**10.4.7 Gas Appliance Startup Procedures.**

**10.4.7.1\*** One at a time, equipment shutoff valves shall be opened, pilot lights shall be lit, and burners shall be adjusted in accordance with each appliance manufacturer's instructions.

**10.4.7.2** The operation of the furnace and water heater thermostats shall be checked and then set to the desired temperatures.

**10.5 Heating Oil Systems.**

**10.5.1** Homes equipped with oil burning furnaces shall have their oil supply tankage and piping installed on site.

**10.5.2** The oil burning furnace manufacturer's instructions shall be consulted for pipe size and installation procedures.

**10.5.3** All oil storage tanks and pipe installations shall meet all applicable local regulations and shall be required to be made only by experienced personnel acceptable to the AHJ.

**10.5.4 Tank Installation Requirements.**

**10.5.4.1** Unless the home is installed in a community with a centralized oil distribution system, an oil storage tank shall be installed outside the home.

**10.5.4.2** The tank shall be located where it is accessible to service and supply and safe from fire and other hazards.

**10.5.4.3** In flood hazard areas, see Chapter 12.

**10.5.5 Leak Test Procedure.**

**10.5.5.1** Before the system is operated, it shall be checked for leaks in the tank and supply piping.

**10.5.5.2** The tank shall be filled to capacity with fuel, and all joints in the system shall be examined for leakage.

**10.6\* Electricity.** A power supply shall be available at the site.

**10.6.1\* Description and Rating of House Wiring.** The home shall be designed for connection to an electrical wiring system rated at 120/240 volts ac.

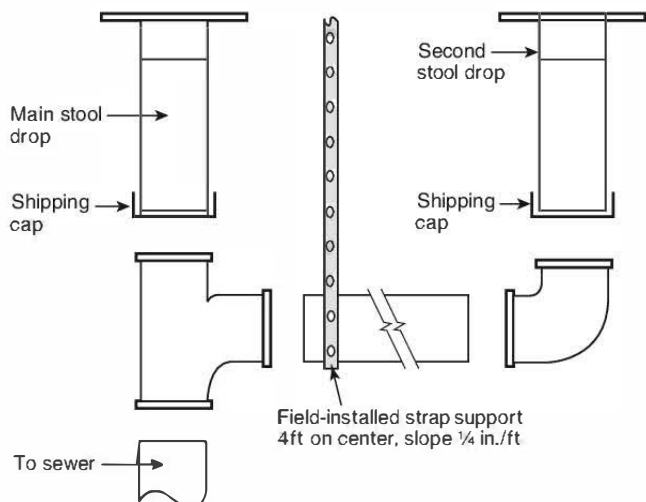

Note: For SI units, 1 ft = 0.3048 m, 1 in. = 25.4 mm.

**FIGURE 10.3.2.1 Drain Pipe Slope and Connections.**

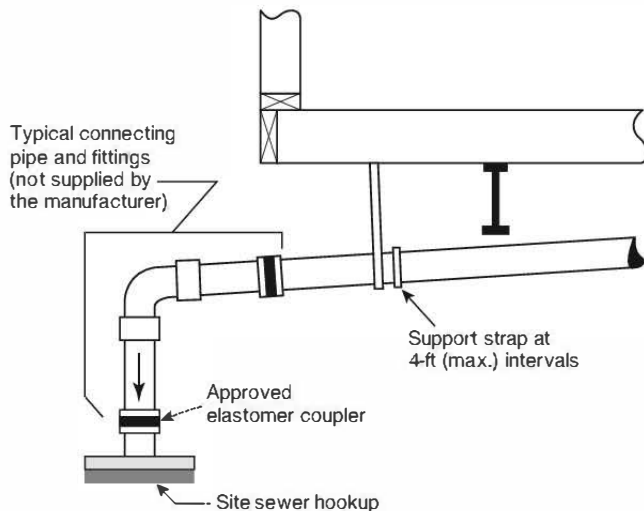

## Notes:

- (1) Fittings in the drainage system that are subject to freezing, such as P-traps in the floor, are protected with insulation by the manufacturer. Insulation must be replaced if it is removed for access to the P-trap.
- (2) For SI units, 1 ft = 0.3048 m.

**FIGURE 10.3.3 Connection to Site Sewer.**

**10.6.2 Electrical Equipment/Installations.** All electrical equipment and installations shall be designed, constructed, and installed in accordance with the applicable provisions of *NFPA 70*, 24 CFR 3280 (MHCSS); or the AHJ, as applicable.

### 10.6.3 Testing.

**10.6.3.1** Each manufactured home shall be subjected to the following tests:

- (1) An electrical continuity test to ensure that metallic parts are properly bonded.
- (2) An operational test of all devices and utilization equipment except water heaters, electric ranges, electric furnaces, dishwashers, clothes washers/dryers, and portable appliances to demonstrate that they are connected and in working order.

**10.6.3.2** Visual verification or other electrical polarity checks shall be used to determine that connections have been made in accordance with the applicable provisions of *NFPA 70*, 24 CFR 3280 (MHCSS); or the AHJ, as applicable.

## Chapter 11 Life Safety Features

**11.1 Smoke Alarms.** Manufacturers shall provide installers with instructions on how to inspect and retest each alarm during installation of the home and provide homeowners with operating and testing information from the alarm manufacturer.

**11.2 Fire Sprinkler Systems.** Manufacturers shall provide installers with instructions on how to perform the following:

- (1) Connect the fire sprinkler systems to a water supply capable of supplying the demand of the fire sprinkler system
- (2) Inspect and retest the fire sprinkler system during installation of the home to ensure the fire sprinkler system is installed in accordance with NFPA 13

- (3) Provide homeowners with the operating and testing information from the fire sprinkler system installer

**11.3 Carbon Monoxide Detectors.** Manufacturers shall provide installers with instructions on how to inspect and retest each alarm during installation of the home and provide homeowners with operating and testing information from the alarm manufacturer. Refer to *NFPA 72* for additional requirements.

**11.4 Fire Separation Distances.** Fire separation distances shall comply with local rules or regulations. In their absence, *NFPA 5000* shall apply.

## Chapter 12 Installation in Flood Hazard Areas

### 12.1\* General.

**12.1.1 Special Techniques Required.** Special elevations and anchoring techniques shall be required when locating a home in a flood hazard area.

**12.1.1.1 Methods and Practices.** Manufactured homes shall be installed using methods and practices that minimize flood damage during the design flood.

**12.1.1.2\* Materials.** Foundation, anchoring, and other installation components at or below the design flood elevation shall be flood damage-resistant.

**12.1.1.3\* Foundation and Anchoring.** Manufactured homes shall be securely attached to a foundation system to resist flotation, collapse, and permanent lateral movement during the design flood.

**12.1.1.4 Elevation.** Manufactured homes shall be elevated in accordance with Section 12.2.

**12.1.1.5 Multiple Flood Hazard Zones.** For homes that lie in more than one flood hazard zone, the entire installation shall be designed and constructed to meet the most restrictive of the elevation, foundation, and other flood requirements.

**12.1.1.6 Floodways.** Installations in floodways shall not be permitted unless it has been demonstrated through hydrologic and hydraulic analyses performed in accordance with standard engineering practice that proposed installations do not result in any increase in flood levels within the community during the occurrence of the base flood discharge.

*Exception: Where FEMA has identified base flood elevations but has not identified a floodway, a home installation shall be permitted, provided it is demonstrated that the cumulative effect of the proposed installation, when combined with all other existing and anticipated development, will not increase the water surface elevation of the base flood more than 1 ft (0.3 m) at any point within the community.*

**12.1.2\* Consultation with AHJ and Registered Professionals.** The AHJ shall be consulted to assure that the home installation conforms to applicable federal, state, and local codes and regulations. A registered professional authorized by law to obtain and certify elevation information shall be consulted in order to meet the requirements of 12.5.1 and 12.5.2. A registered professional engineer or architect shall be consulted in order to meet the requirements of 12.5.3, 12.5.4, and 12.5.5.



## 12.2 Lowest Floor Elevation.

### 12.2.1 Installations in New Manufactured Home Parks, in Expansions to Existing Manufactured Home Parks, or Outside Existing Manufactured Home Parks.

**12.2.1.1 Flood Hazard Areas Classified as V Zones.** Homes shall be installed such that the bottom of the lowest horizontal supporting member of the lowest floor is at or above the design flood elevation. Foundations and anchoring shall comply with 12.3.1 and 12.3.2.1.

**12.2.1.2 Flood Hazard Areas Classified as A Zones.** Homes shall be installed such that the bottom of the longitudinal chassis frame beams are at or above the design flood elevation. Foundations and anchoring shall comply with 12.3.1 and 12.3.2.2.

### 12.2.2\* Installations in Existing Manufactured Home Parks.

**12.2.2.1** New, replacement, and substantially improved homes shall be installed in accordance with one of the following:

- (1) With the bottom of the chassis frame beam no less than 36 in. (0.9 m) in height above grade
- (2) In conformance with the elevation requirements of 12.2.1

**12.2.2.2** Foundations and anchoring shall comply with 12.3.1 and 12.3.3.

*Exception: Replacement or repair of a substantially damaged (by flood) manufactured home in an existing park shall be elevated with the lowest floor at or above the design flood elevation, as specified in 12.2.1.*

**12.2.3 Lowest Floor Inspection and Elevation Certification.** All installations shall be subject to the inspection and elevation certification requirements in 12.5.1 and 12.5.2.

## 12.3 Foundations and Anchoring.

**12.3.1 Design Flood Loads and Conditions.** Manufactured home foundations and anchoring systems shall resist flotation, collapse, and permanent lateral movement, including the effects of scour and erosion, during the design flood. Design flood loads shall be determined using Section 5 of ASCE/SEI 7, *Minimum Design Loads for Buildings and Other Structures*. These requirements shall be in addition to applicable state and local anchoring requirements for resisting wind loads.

### 12.3.2 Installations in New Manufactured Home Parks, in Expansions to Existing Manufactured Home Parks, or Outside Existing Manufactured Home Parks.

**12.3.2.1 Flood Hazard Areas Classified as V Zones.** Homes shall be installed on a pile or column foundation that is capable of resisting the simultaneous effects of flood and wind and meeting the requirements of 12.3.1. Use of fill for structural support shall be prohibited. The foundation and anchoring shall be subject to the certification requirements of 12.5.3.

**12.3.2.2 Flood Hazard Areas Classified as A Zones.** Homes shall be installed on a foundation that is capable of meeting the requirements of 12.3.1. If the foundation is composed of solid walls and forms an enclosure below the home, the walls shall be equipped with flood openings in compliance with 12.4.2.2.

### 12.3.3 Installations in Existing Manufactured Home Parks.

**12.3.3.1 Flood Hazard Areas Classified as V Zones.** Support by reinforced piers or other foundation elements of at least equivalent strength, which are no less than 36 in. (0.9 m) in height above grade, shall be permitted for installations in an existing manufactured home park, provided the foundation is capable of resisting lateral flood loads in accordance with 12.3.1.

*Exception: Replacement or repair of a substantially damaged (by flood) manufactured home in an existing park shall be elevated on a pile or column foundation with its lowest floor at or above the design flood elevation, in compliance with 12.2.1.1 and 12.3.2.1.*

**12.3.3.2 Flood Hazard Areas Classified as A Zones.** Support by reinforced piers or other foundation elements of at least equivalent strength, which are no less than 36 in. (0.9 m) in height above grade, shall be permitted for installations in an existing manufactured home park, provided the foundation is capable of resisting lateral flood loads in accordance with 12.3.1.

*Exception: Replacement or repair of a substantially damaged (by flood) manufactured home in an existing park shall be elevated on a foundation to a height at or above the design flood elevation, in compliance with 12.2.1.2 and 12.3.2.2.*

## 12.4 Installation Procedures.

**12.4.1 Use of Fill.** Fill shall be permitted to be used to provide structural support to an A zone home installation. Any such fill shall be compacted, in accordance with 5.5.1, and protected against scour and erosion during the design flood event. Fill shall not be used to provide structural support to a V zone home installation.

### 12.4.2 Obstructions and Enclosures Below the Design Flood Elevation.

**12.4.2.1 Flood Hazard Areas Classified as V Zones.** The installation shall have the space below the home's chassis frame beam either free of obstructions or constructed with non-supporting breakaway walls, open wood latticework, insect screening, or skirting that will collapse under wind and water loads without causing collapse, displacement, or other structural damage to the elevated home or supporting foundation system. Breakaway walls shall be subject to the certification requirements of 12.5.4.

### 12.4.2.2 Flood Hazard Areas Classified as A Zones.

**12.4.2.2.1** Solid walls forming enclosed areas below the lowest floor shall be equipped with flood openings that permit the automatic entry and exit of floodwaters. The following types of flood openings shall be permitted:

- (1) Flood openings that comply with the non-engineered flood opening requirements of 2.7.2.1 of ASCE/SEI 24, *Flood Resistant Design and Construction*. The certification in 12.5.5 shall not be required.
- (2) Flood openings that comply with the engineered flood opening requirements of 2.7.2.2 of ASCE/SEI 24. The certification in 12.5.5 shall be required.

**12.4.2.2.2** Installation of skirting shall not trigger the requirement for flood openings, provided the skirting meets the following conditions:

- (1) Does not provide structural support to the home or its foundation
- (2) Will collapse under wind and water loads less than the base flood event, without causing structural damage to the home or foundation

### 12.5 Post-Installation Considerations.

**12.5.1 Lowest Floor Inspection.** For manufactured homes installed on a manufactured home site located wholly or partly in a flood hazard area, a lowest floor inspection and certification of the elevation of the floor shall be required.

**12.5.2\* Elevation Certification.** Certification of the lowest floor reference (*see 3.3.19*) shall be required for new, replacement, and substantially improved homes in all flood hazard areas. An elevation certificate specified by the AHJ shall be completed by a licensed or registered professional authorized by law to certify elevation information.

**12.5.2.1** The certificate shall contain the following:

- (1) The bottom of the lowest horizontal supporting member elevation (in V zones) or the elevation of the bottom of the chassis frame beam (in A zones)
- (2) The lowest elevation of machinery and equipment servicing the home
- (3) Adjacent grade elevations
- (4) Flood opening elevation information

**12.5.2.2** The certificate shall be submitted to the AHJ. Elevations shown on the certificate shall be referenced to the datum shown on the jurisdiction's flood hazard map.

**12.5.3 V Zone Certification.** A registered professional engineer or architect shall certify the following:

- (1) The foundation and anchorage design and methods of construction to be used are in accordance with accepted standards of practice to meet the loading and stability requirements of 12.3.1 or 12.3.2.1.
- (2) The lowest floor elevation meets the requirements of 12.2.1.1 or 12.2.2.

**12.5.4 Breakaway Wall Certification.** Breakaway walls below the design flood elevation that are designed to fail at loads greater than 20 psf (0.96 kN/m<sup>2</sup>) acting perpendicular to the wall shall be certified by a registered professional engineer or architect. Such design certification shall include the following:

- (1) The breakaway wall is designed to collapse from a flood load less than that which will occur during the base flood.
- (2) The elevated portion of the structure and the supporting foundation system shall resist collapse, displacement, or other structural damage due to the effects of base flood loads and load combinations.

**12.5.5 Flood Opening Certification.** For enclosed areas below the design flood elevation not meeting the non-engineered flood opening requirements of 2.7.2.1 of ASCE/SEI 24, *Flood Resistant Design and Construction*, a registered professional engineer or architect shall prepare a certification that the flood openings will allow for the automatic entry and exit of floodwaters, will allow the equalization of hydrostatic forces, and will meet the engineered flood opening requirements of 2.7.2.2 of ASCE/SEI 24.

### 12.6 Preparation of Appliances.

**12.6.1 Outside Appliances.** Appliances installed on the manufactured home site shall be anchored and shall be elevated to or above the bottom of the chassis frame beam.

**12.6.2 Air Inlets and Outlets.** Air inlets and outlets shall be located at or above the bottom of the chassis frame beam.

*Exception: Clothes dryer outlets below the bottom of the chassis frame beam.*

### 12.7 Utility Systems.

**12.7.1** In flood hazard areas, the fuel storage tank shall be anchored and elevated to or above the design flood elevation or anchored and designed to prevent flotation, collapse, or permanent lateral movement during the design flood.

**12.7.2\*** Water, drainage, plumbing, electrical, gas, HVAC, ductwork, and other utilities, machinery, and equipment shall be at or above the elevation of the bottom of the chassis frame beam or, if located below this elevation, shall be flood damage-resistant and designed and installed to prevent water from entering or accumulating within the components and to resist flood loads, including the effects of buoyancy.

*Exception: This standard shall not prohibit the installation of non-flood-resistant crossover ductwork, main HVAC supply and return ducts connected to the home's duct systems, and clothes dryer ducts below the bottom of the chassis frame beam.*

## Chapter 13 Seismic Provisions for Prescriptive Design of Support Systems

**13.1 Scope.** In addition to the other requirements of this standard, support systems for manufactured homes located in seismic design categories D<sub>0</sub>, D<sub>1</sub>, D<sub>2</sub>, and E, and using the prescriptive design method in accordance with 4.5.1.1, shall meet the requirements of this chapter. Alternately, support systems shall be permitted to conform to engineered design methods, in accordance with 4.5.1.2, or equivalency provisions in accordance with 4.5.1.3. The provisions of Chapter 13 shall be applied to manufactured homes that conform to the limitations in 13.1.1 through 13.1.6. Support systems for homes not meeting these limitations shall be provided with an engineered design in accordance with 4.5.1.2 or equivalent system in accordance with 4.5.1.3.

**13.1.1** The grade slope shall not exceed 1 vertical to 10 horizontal.

**13.1.2** The maximum change in grade height on opposite sides of a foundation wall shall not exceed 1 ft (305 mm) for concrete or concrete masonry foundation walls. For wood cripple walls, no change in grade height shall be permitted.

**13.1.3** The manufactured home shall not exceed one story.

**13.1.4** The width of each manufactured home section shall not be less than 11 ft 4 in. (3450 mm), nor exceed 16 ft (4880 mm), and shall have a minimum chassis beam spacing of 7 ft 10 in. (2390 mm).

**13.1.5** The roof slope shall not be less than ½ in./ft (1:24), nor exceed 4.4 in./ft (1:2.72).

**13.1.6** The average section dead load of the manufactured home, measured per foot of length, shall not be less than 260 lb/ft (3.79 kN/m), nor exceed 470 lb/ft (6.86 kN/m) for single-section homes. The average multisection dead load of the manufactured home, measured per foot of length, shall not be less than 500 lb/ft (7.30 kN/m), nor exceed 895 lb/ft (13.06 kN/m) for multisection homes.

### 13.2 Minimum Prescriptive Support System Requirements.

**13.2.1** Excavations shall be made to firm, undisturbed bearing soil containing no organic materials or unstable soils. The bottom of footing shall extend to the greater of the following:

- (1) 12 in. (300 mm) below the lowest adjacent undisturbed grade level
- (2) The footing depth required by Chapter 13
- (3) Below the frost line

**13.2.2** Both the top and bottom of isolated footings shall be level. Continuous footings shall be level or stepped such that the bottom and top of the footings are level. The maximum rise in a stepped footing shall be 18 in. (457 mm). The minimum run between rises shall be 36 in. (914 mm).

**13.3 Prescriptive Pier Support Systems.** The provisions of Section 13.3 shall apply to piers located along and attached to the chassis beams and providing both vertical load and lateral force support for a manufactured home.

**13.3.1** Pier construction shall be of concrete masonry, not less than 16 in. (406 mm) nominal square in plan and supported on a concrete footing, and shall meet or exceed the requirements of Figure 13.3.1.

**13.3.2** The height of piers above lowest adjacent grade shall not vary by more than 2 ft (610 mm), and no pier shall extend to more than 5 ft (1524 mm) above adjacent grade.

**13.3.3** The length and width of the pier footing shall not be less than required by Table 13.3.3, based on the applicable allowable stress design soil-bearing strength.

**13.3.4** All cells of the concrete masonry units shall be solid grouted with grout having a 28-day compressive strength of not less than 2000 psi (13,789 kN/m<sup>2</sup>).

**13.3.5** Each concrete masonry pier shall be provided with not less than two No. 4 vertical reinforcing bars, located in diagonally opposite corners. The vertical bars shall have standard hooks of not less than 8 in. (203 mm) provided in the concrete footing and shall extend to within 2 in. (51 mm) of the top of the pier. See Figure 13.3.1 for required placement.

**13.3.6** Anchorage shall be provided between the support system and manufactured home, capable of resisting the greater of the loads and forces specified in NFPA 501; Table 13.3.6 of this standard; or the reactions specified by the home manufacturer. The chassis beam shall not be cut, drilled, or otherwise modified without specific approval of the AHJ and the home manufacturer.

**13.3.7** Non-shrink Portland cement grout with a 28-day compressive strength of not less than 3000 psi (20,670 kN/m<sup>2</sup>) shall be provided between the chassis beam and the pier, when required to obtain full bearing of the chassis beam. Grout shall be permitted to be dry-packed following home placement. Height of grout shall not exceed 2 in. (51 mm).

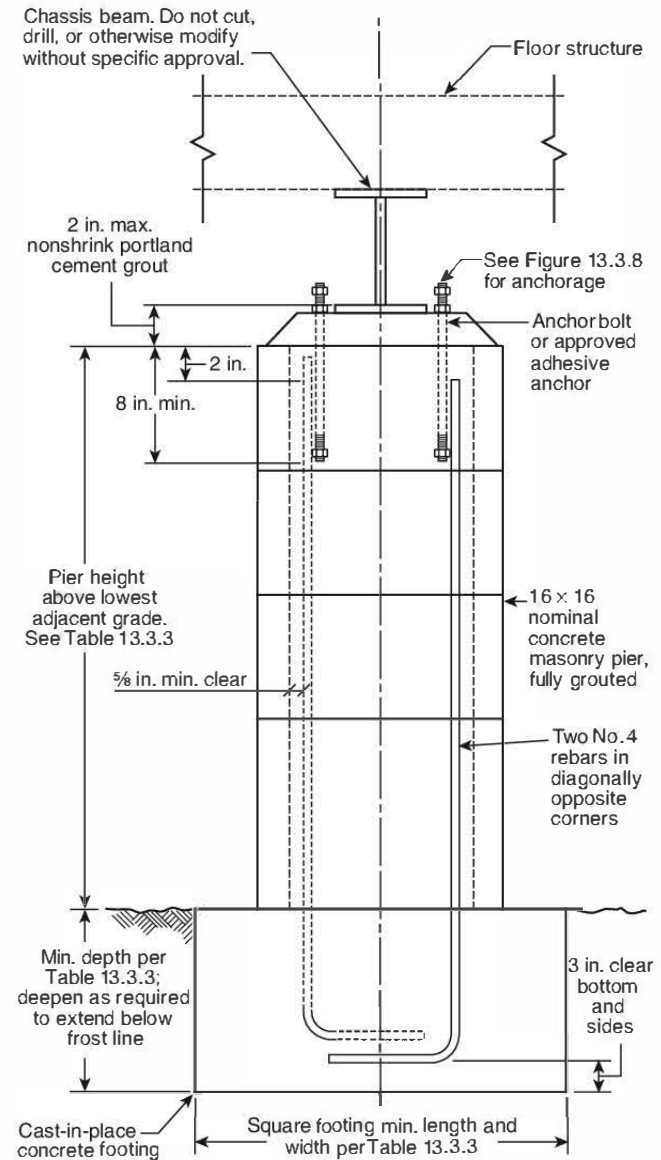

Note: For SI units, 1 in. = 25.4 mm.

**FIGURE 13.3.1 Concrete Masonry Pier Construction Requirements.**

**13.3.8** Where anchorage requirements from the home manufacturer are not available, required anchorage shall be permitted to use four ½ in. (12.7 mm) diameter anchor bolts on each pier with steel shims and plates, in accordance with Figure 13.3.8. See Figure 13.3.1 for balance of anchor bolt information.

**13.4 Prescriptive Foundation Wall Support Systems.** The provisions of Section 13.4 shall apply to foundation walls located at the manufactured home perimeter and providing lateral force support of manufactured homes. Where foundations walls are provided in accordance with Section 13.4, interior support shall be permitted to conform to applicable provisions of Chapter 6.

Table 13.3.3 Pier Minimum Square Footing Side Dimension and Depth

| Width   | Pier Height<br>(ft)* | Pier Spacing<br>Along Chassis<br>(ft) | Allowable Soil-Bearing Pressure (psf) |                     |                     |
|---|----------------------|---------------------------------------|---------------------------------------|---------------------|---------------------|
|   |                      |                                       | 1000                                  | 1500                | 2000                |
| <b>Seismic or 90 mph Wind</b>                     |                      |                                       |                                       |                     |                     |
| Single  | 3                    | 4                                     | 3'-0" × 3'-0" × 16"                   | —                   | —                   |
|   |                      | 7                                     | 4'-0" × 4'-0" × 20"                   | —                   | —                   |
|   |                      | 10                                    | 4'-6" × 4'-6" × 20"                   | 4'-0" × 4'-0" × 20" | —                   |
| Double  | 3                    | 4                                     | 3'-0" × 3'-0" × 16"                   | 2'-6" × 2'-6" × 16" | —                   |
|   |                      | 7                                     | 3'-6" × 3'-6" × 20"                   | —                   | —                   |
|   |                      | 10                                    | 4'-0" × 4'-0" × 20"                   | —                   | —                   |
| Single  | 5                    | 4                                     | 3'-6" × 3'-6" × 20"                   | —                   | —                   |
|   |                      | 7                                     | 4'-6" × 4'-6" × 20"                   | 4'-0" × 4'-0" × 20" | —                   |
|   |                      | 10                                    | 5'-0" × 5'-0" × 20"                   | 4'-6" × 4'-6" × 20" | —                   |
| Double  | 5                    | 4                                     | 3'-0" × 3'-0" × 16"                   | —                   | —                   |
|   |                      | 7                                     | 3'-6" × 3'-6" × 20"                   | —                   | —                   |
|   |                      | 10                                    | 4'-0" × 4'-0" × 20"                   | —                   | —                   |
| <b>90 mph Wind plus Non-Coastal A-Zone Flood†</b> |                      |                                       |                                       |                     |                     |
| Single  | 3                    | 4                                     | 3'-6" × 3'-6" × 20"                   | —                   | —                   |
|   |                      | 7                                     | 4'-0" × 4'-0" × 20"                   | —                   | —                   |
|   |                      | 10                                    | 4'-6" × 4'-6" × 20"                   | —                   | —                   |
| Double  | 3                    | 4                                     | 3'-0" × 3'-0" × 16"                   | —                   | —                   |
|   |                      | 7                                     | 4'-0" × 4'-0" × 20"                   | —                   | —                   |
|   |                      | 10                                    | 4'-6" × 4'-6" × 20"                   | —                   | —                   |
| Single  | 5                    | 4                                     | 4'-0" × 4'-0" × 20"                   | —                   | 3'-6" × 3'-6" × 20" |
|   |                      | 7                                     | 4'-6" × 4'-6" × 20"                   | —                   | —                   |
|   |                      | 10                                    | 5'-0" × 5'-0" × 20"                   | —                   | —                   |
| Double  | 5                    | 4                                     | 3'-6" × 3'-6" × 20"                   | —                   | —                   |
|   |                      | 7                                     | 4'-0" × 4'-0" × 20"                   | —                   | —                   |
|   |                      | 10                                    | 4'-6" × 4'-6" × 20"                   | —                   | —                   |
| <b>90 mph Wind plus Coastal A-Zone Flood†</b>     |                      |                                       |                                       |                     |                     |
| Single  | 3                    | 4                                     | 3'-6" × 3'-6" × 20"                   | —                   | —                   |
|   |                      | 7                                     | 4'-0" × 4'-0" × 20"                   | —                   | —                   |
|   |                      | 10                                    | 4'-6" × 4'-6" × 20"                   | —                   | —                   |
| Double  | 3                    | 4                                     | 3'-6" × 3'-6" × 20"                   | —                   | —                   |
|   |                      | 7                                     | 4'-0" × 4'-0" × 20"                   | —                   | —                   |
|   |                      | 10                                    | 4'-6" × 4'-6" × 20"                   | —                   | —                   |
| Single  | 5                    | 4                                     | 4'-0" × 4'-0" × 20"                   | —                   | 3'-6" × 3'-6" × 20" |
|   |                      | 7                                     | 4'-6" × 4'-6" × 20"                   | —                   | —                   |
|   |                      | 10                                    | 5'-0" × 5'-0" × 20"                   | —                   | —                   |
| Double  | 5                    | 4                                     | 4'-0" × 4'-0" × 20"                   | 3'-6" × 3'-6" × 20" | —                   |
|   |                      | 7                                     | 4'-6" × 4'-6" × 20"                   | —                   | 4'-0" × 4'-0" × 20" |
|   |                      | 10                                    | 5'-0" × 5'-0" × 20"                   | 4'-6" × 4'-6" × 20" | —                   |

For SI units, 1 in. = 25.4 mm, 1 ft = 0.3048 m, 1 psf = 47.9 N/m<sup>2</sup>.

Notes:

(1) Top of concrete footing not to extend above finished grade. Provide greater footing depth where required to satisfy local frost depth requirements. Circular footing of equal area is permitted, with a minimum diameter equal to 1.13 times the tabulated side dimension.

(2) Increase footing depth or provide erosion protection around piers in flood hazard areas where the maximum predicted scour depth exceeds 16 in. (406 mm).

\*Pier height measured from top of grade.

†Flood velocities not greater than 5 ft/sec (1.52 m/sec) with depths not exceeding the elevation of the lowest edge of the longitudinal support frame.

**Table 13.3.6 Pier to Chassis Seismic/Wind Anchorage Forces**

| Width  | Pier Height (ft) | Maximum Pier Spacing (ft) | Horizontal                        | Vertical                           |
|--------|------------------|---------------------------|-----------------------------------|------------------------------------|
|        |                  |                           | Seismic/Wind Force Each Pier (lb) | Seismic/Wind Force Each Pier (lb)* |
| Single | 3                | 4                         | 320                               | 720                                |
|        |                  | 7                         | 560                               | 1250                               |
|        |                  | 10                        | 800                               | 1790                               |
| Double | 3                | 4                         | 290                               | 860                                |
|        |                  | 7                         | 440                               | 1510                               |
|        |                  | 10                        | 600                               | 2150                               |
| Single | 5                | 4                         | 350                               | 720                                |
|        |                  | 7                         | 620                               | 1250                               |
|        |                  | 10                        | 880                               | 1790                               |
| Double | 5                | 4                         | 340                               | 860                                |
|        |                  | 7                         | 490                               | 1510                               |
|        |                  | 10                        | 650                               | 2150                               |

For SI units, 1 lb = 0.454 kg, 1 ft = 0.3048 m.

\*Based on 14 ft section width. Multiply by 1.15 for 16 ft section width.

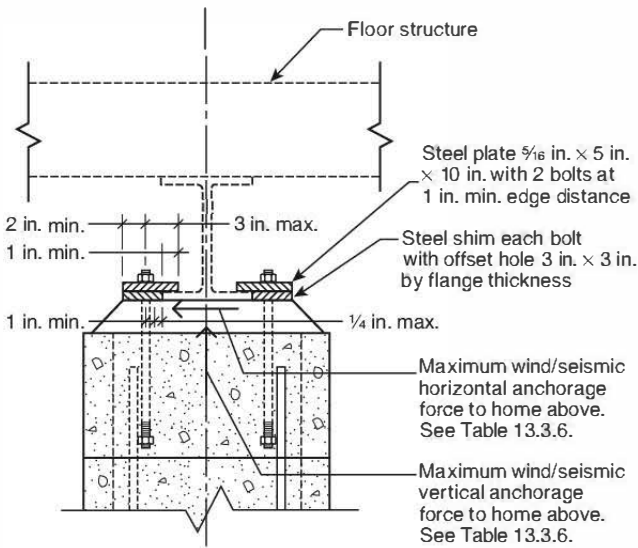

Notes:  
 (1) For SI units, 1 in. = 25.4 mm.  
 (2) For remainder of information, see Figure 13.3.1.

**FIGURE 13.3.8 Anchorage Requirements for Shims and Plates.**

**13.4.1** Foundation stem wall construction shall be of concrete or concrete masonry units (CMUs) supported on a continuous concrete footing, the stem width shall be not less than 6 in. (152 mm) nominal, and construction shall not be less than that designated in Figure 13.4.1(a) and Figure 13.4.1(b).

**13.4.2** The height of foundation walls shall not vary by more than 2 ft (610 mm), and no foundation wall shall extend to more than 3 ft (914 mm) above lowest adjacent grade.

**13.4.3** The foundation wall footing shall be continuous.

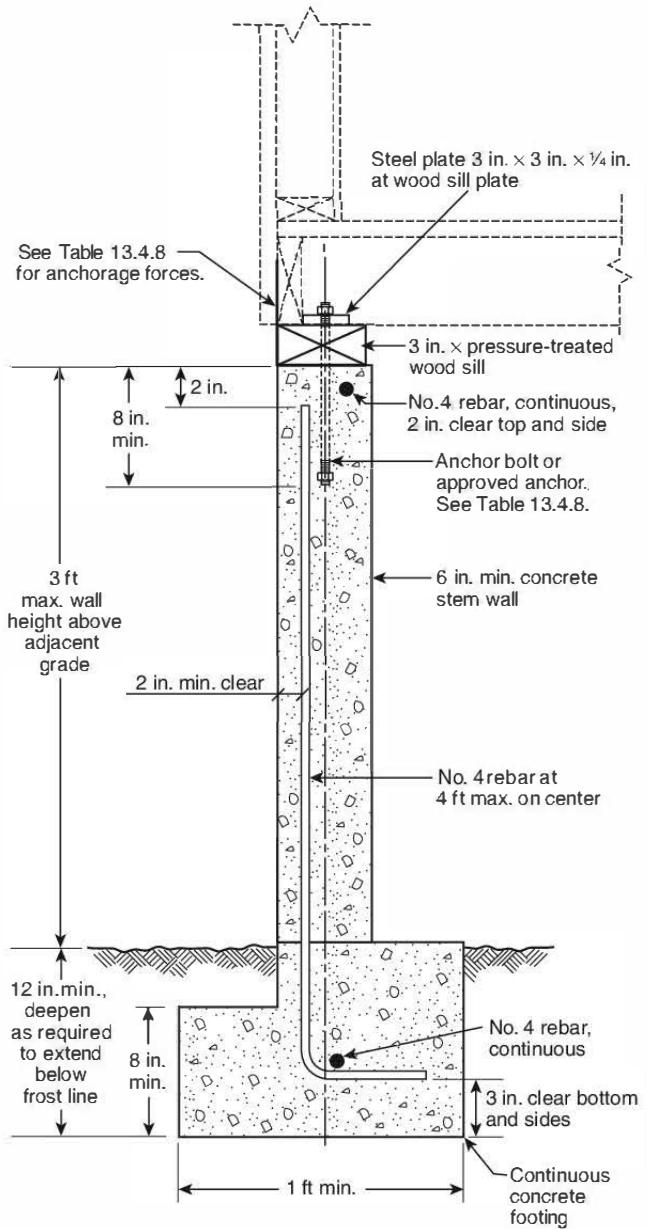

Note: For SI units, 1 in. = 25.4 mm.

**FIGURE 13.4.1(a) Concrete Foundation Stem Wall Construction.**

**13.4.4** The foundation stem wall shall be provided in lengths not less than 6 ft (1829 mm), except that foundation vents, with a height not exceeding one third of the stem wall height, shall be permitted to be provided within the 6 ft (1829 mm) length. Crawl space access shall be provided as required by other provisions of this standard.

**13.4.5** The concrete masonry units (CMUs) need not be solid grouted; however, grouting shall be provided at vertical cells with reinforcing steel and a continuous bond beam for not less than the top 8 in. (203 mm) of the stem wall. Grout shall have

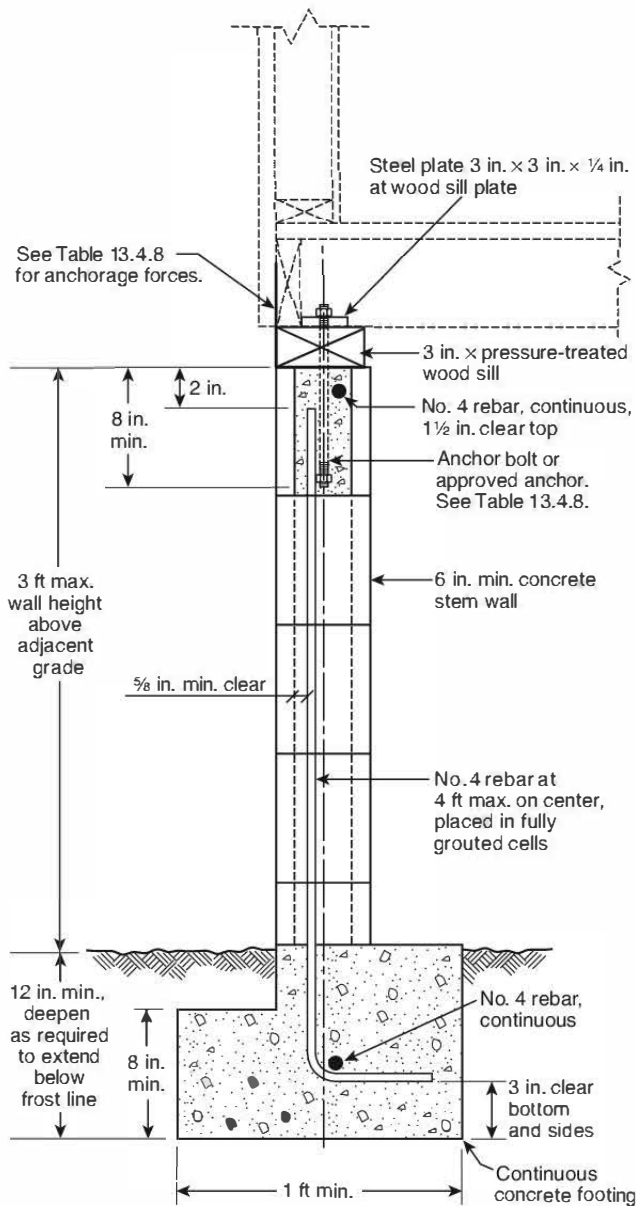

Note: For SI units, 1 in. = 25.4 mm.

**FIGURE 13.4.1(b) CMU Foundation Stem Wall Construction.**

a 28-day compressive strength of not less than 2000 psi (13,789 kN/m<sup>2</sup>).

**13.4.6** Each concrete or concrete masonry foundation wall shall be provided with not less than No. 4 vertical reinforcing bars at a spacing not exceeding 4 ft (1219 mm), with a standard hook of not less than 8 in. (203 mm) in the footing. See Figure 13.4.1(a) and Figure 13.4.1(b) for required placement. Each foundation shall have not less than one No. 4 continuous in the footing and one No. 4 continuous within 8 in. (203 mm) of the top of the wall. Lap splices for No. 4 bars shall be not less than 24 in. (610 mm) straight and shall provide not less than a 12 in. (305 mm) bend around corners.

**13.4.7** Anchorage shall be provided between the support system and manufactured home, capable of resisting the greater of the loads and forces specified in NFPA 501; Table 13.4.7 of this standard; and the reactions specified by the home manufacturer.

**13.4.8** Where anchorage requirements from the home manufacturer are not available, required anchorage shall be permitted to use the anchor bolt and framing plates in accordance with Table 13.4.8. Each anchor bolt shall be provided with a steel plate washer not less than 1/4 in. x 3 in. x 3 in. (6.3 mm x 76 mm x 76 mm), with a hole diameter of 1/16 in. (1.74 mm) and installed with a standard cut washer. See Figure 13.4.1(a) and Figure 13.4.1(b) for placement.

**13.4.9** Foundation crawl-space ventilation and access openings meeting the requirements of 8.8.2 shall be provided in the foundation wall. When located in a flood hazard area, flood openings conforming to ASCE/SEI 24, *Flood Resistant Design and Construction*, Section 2.6.2.1, shall be provided in the foundation wall, or the requirements of ASCE/SEI 24, Section 2.6.2.2, shall be met.

**13.5 Prescriptive Wood Cripple Wall Support Systems.** The provisions of Section 13.5 shall apply to wood framed cripple walls at the manufactured home perimeter and providing lateral force support of manufactured homes. Where foundation walls are provided in accordance with Section 13.5, interior support shall be permitted to conform to applicable provisions of Chapter 6.

**Table 13.4.7 Manufactured Home Perimeter to Foundation or Cripple Wall Seismic/Wind Anchorage Forces**

| Home Width | Wall Location | Horizontal Seismic/Wind Force per Foot Wall (Shear) (lb/ft) | Vertical Seismic/Wind Force per Foot Wall (Uplift) (lb/ft) |
|------------|---------------|---|--|
| Single     | End           | 510   | 50   |
|            | Side          | 70  | 120  |
| Double     | End           | 260   | 50   |
|            | Side          | 140   | 150  |

For SI units, 1 lb/ft = 1.5 kg/m.

**Table 13.4.8 Manufactured Home Minimum Perimeter to Foundation Wall Seismic/Wind Anchorage**

| Home Width | Wall Location | Maximum Spacing for 1/2 in. Anchor Bolt Anchoring Sill to Foundation Wall (in.) | Maximum Spacing for Framing Plate with Shear and Uplift Capacity (in.)* |
|------------|---------------|---|---|
| Single     | End           | 16  | 12  |
|            | Side          | 48  | 42  |
| Double     | End           | 32  | 18  |
|            | Side          | 32  | 18  |

For SI units, 1 in. = 25.4 mm.

\*Not less than 18 gauge galvanized plate, fastened to sill and home with not less than six 8d common short nails each.

**13.5.1** A continuous concrete perimeter footing shall be provided, with a width not less than 12 in. (305 mm). The concrete shall extend not less than 8 in. (203 mm) above the highest adjacent grade. Construction shall not be less than that designated in Figure 13.5.1.

**13.5.2** A continuous perimeter cripple wall shall be provided, constructed in accordance with Figure 13.5.1. Transverse end walls shall be fully sheathed with no crawl-space access or other openings. Longitudinal walls shall have fully sheathed sections of not less than 8 ft (2438 mm) in length, and totaling not less than 50 percent of the longitudinal wall length. Required access openings and ventilation openings shall be provided in the longitudinal walls.

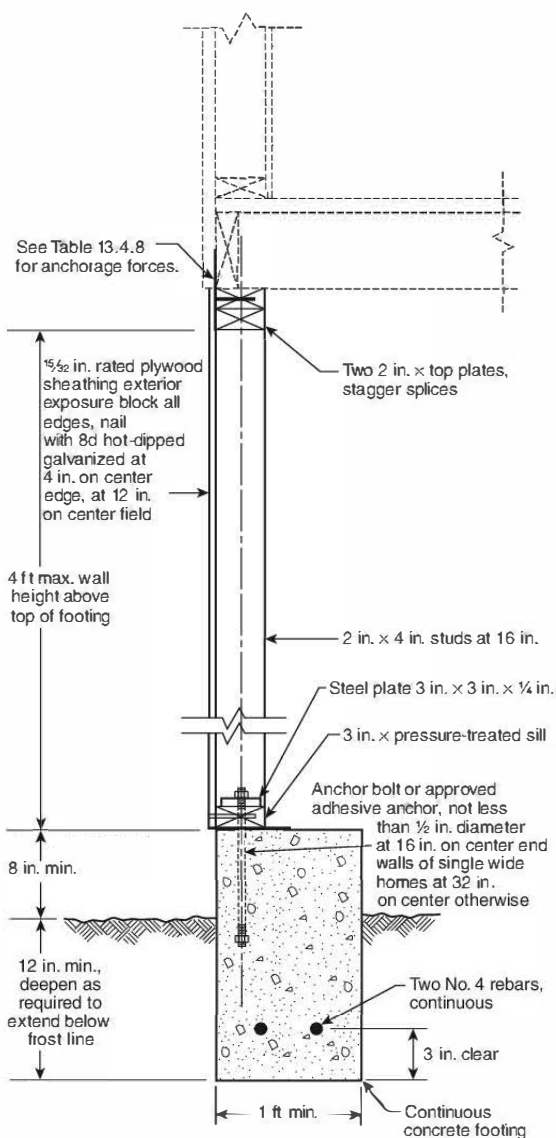

Note: For SI units, 1 in. = 25.4 mm, 1 ft = 0.3048 m.

**FIGURE 13.5.1** Continuous Concrete Perimeter Footing Requirements.

**13.5.3** Where home length exceeds 60 ft (18.3 m), two interior transverse shear walls with continuous footings shall be added, with spacing between walls not exceeding 30 ft (9.1 m). Access openings shall be provided at the center of transverse interior footings.

**13.5.4** The height of the cripple walls shall not exceed 4 ft (1219 mm) above the top of footing.

**13.5.5** The concrete footing shall be provided with not less than two continuous No. 4 reinforcing bars. See Figure 13.5.1 for placement. Lap splices for No. 4 bars shall be not less than 24 in. (610 mm) straight and shall provide not less than a 12 in. (305 mm) bend around corners.

**13.5.6** Anchorage between the cripple wall sill plate and the concrete footing shall be provided with not less than  $\frac{1}{2}$  in. (12.7 mm) diameter anchor bolts, starting not more than 8 in. (203 mm) from the end of each foundation sill. Anchor bolts shall be embedded not less than 8 in. (203 mm) into the concrete. Anchor bolt spacing shall not exceed 16 in. (406 mm) on center for end walls of single-wide homes, and 32 in. (813 mm) on center for other walls. Each anchor bolt shall be provided with a steel plate washer not less than  $\frac{1}{4}$  in. x 3 in. x 3 in. (6.3 mm x 76 mm x 76 mm), with a hole diameter of  $\frac{1}{16}$  in. (1.74 mm) and installed with a standard cut washer. See Figure 13.5.1 for placement.

**13.5.7** Anchorage shall be provided between the cripple wall and manufactured home, capable of resisting the greater of the loads and forces specified in NFPA 501; Table 13.4.7 of this standard; and the reactions specified by the home manufacturer.

**13.5.8** Where anchorage requirements from the home manufacturer are not available, required anchorage between the cripple wall and the manufactured home shall be permitted to use framing plates in accordance with Table 13.4.8.

**13.5.9** Foundation crawl-space ventilation and access openings meeting the requirements of 8.8.2 shall be provided in the cripple wall. When located in a flood hazard area, flood openings conforming to ASCE/SEI 24, *Flood Resistant Design and Construction*, Section 2.6.2.1 shall be provided in the cripple wall, or the requirements of ASCE/SEI 24, Section 2.6.2.2 shall be met.

## Chapter 14 Seismic Installation and Equipment Bracing Requirements

**14.1 General.** In addition to the other requirements of this standard, installation and equipment bracing in manufactured homes located in seismic design categories D<sub>0</sub>, D<sub>1</sub>, D<sub>2</sub>, and E shall meet the additional requirements of Chapter 14.

**14.2 Site-Installed Water Heaters.** Site-installed water heaters shall be provided with seismic bracing straps installed in accordance with the manufacturer's recommendations.

**14.3 Site-Installed Equipment.** Other site-installed equipment weighing more than 100 lb (445 N) shall be anchored to resist horizontal seismic forces. Forces shall be calculated in accordance with ASCE/SEI 7, *Minimum Design Loads for Buildings and Other Structures*. Alternately, the horizontal force shall be permitted to be taken as equal to the equipment weight and assumed to act at mid-height of the equipment.

**14.4 Utility Attachments.** Utility attachments to the manufactured home shall be capable of accommodating the anticipated seismic and wind displacement of the support and anchorage systems.

## Chapter 15 Prescriptive Flood Provision Designs

**15.1\* Scope.** Manufactured homes located in flood hazard areas shall be installed per the manufacturer's installation instructions.

**15.1.1** When the manufacturer's installation instructions are not available or when the manufacturer's installation instructions are available but do not specifically state that they are applicable to homes placed in flood hazard areas, the prescriptive designs of Chapter 15 shall be used.

**15.1.2** Alternatively, support systems shall be permitted to conform to engineered design methods in accordance with 4.5.1.2 or the equivalency provisions in accordance with 4.5.1.3.

**15.2 Anchorage and Support Materials.** Piers, foundation walls, and other anchorages and supports for homes sited in flood hazard areas shall be constructed using materials in accordance with 12.1.1.2.

**15.3 General Limitations.** The provisions of Chapter 15 shall be applied to manufactured homes that conform to the general limitations in 15.3.1 through 15.3.1.2. Prescriptive ground anchor support and anchorage system shall comply with Section 15.4. Prescriptive foundation wall support and anchorage systems shall comply with Section 15.5.

**15.3.1\*** The manufactured homes installed per the prescriptive designs of Chapter 15 shall be located outside of V zones, floodways, and all areas subjected to breaking waves 18 in. (0.46 m) high or greater during the design flood.

**15.3.1.1** Manufactured homes installed per the prescriptive designs of Chapter 15 shall be installed such that the bottom of the manufactured home's chassis or I-beam is located at or above the design flood elevation.

**15.3.1.2** The following conditions shall be applicable:

- (1) Flood velocities during a design flood are 5 ft/sec or less.
- (2) Pier heights required to elevate the bottom of the supporting chassis frame beam per 12.2.1.1 are 36 in. (0.91 m) or less.
- (3) Frame spacing for homes is a minimum of 92.5 in. (2.35 m) and a maximum of 99.5 in. (2.53 m).
- (4) The manufactured home has a wall height less than or equal to 8 ft (2.44 m) and has a minimum weight of 20 lb/ft<sup>2</sup> (0.14 MPa).
- (5) The manufactured home is located in an area where the roof snow load is 30 lb/ft<sup>2</sup> (0.21 MPa) or less.

**15.4 Prescriptive Ground Anchor Support and Anchorage System.** The provisions of Section 15.3 shall apply to support and anchorage systems using piers and ground anchors. Ground anchors shall be certified for use in the soils where the home is located under saturated soil conditions.

**15.4.1 Specific Limitation — Ground Anchor Support and Anchorage System.**

**15.4.1.1** Manufactured homes shall be single or double units with section widths as listed in Table 7.5.2.4.1.1(a) through Table 7.5.2.4.1.1(d).

**15.4.1.2** Manufactured homes shall be single or double units with roof slopes between 3:12 and 7:12.

**15.4.2 Transverse Anchorage.**

**15.4.2.1** Transverse anchorage for manufactured homes located in NFPA 501, Wind Zone I shall be installed in accordance with Table 7.5.2.4.1.1(a) and Figure 7.5.2.4.1.1(a) and Figure 7.5.2.4.1.1(b).

**15.4.2.2** Transverse anchorage for manufactured homes located in NFPA 501, Wind Zones II, III, and IV shall be installed in accordance with Table 7.5.2.4.1.1(b) through Table 7.5.2.4.1.1(d) and Figure 7.5.2.4.1.1(a) and Figure 7.5.2.4.1.1(c).

**15.4.3 Longitudinal Anchorage.** Longitudinal anchorage for all homes shall be installed per Table 7.5.2.4.2.2 and Figure 7.5.2.4.1.1(a).

**15.4.4 Piers.** Piers for homes placed in flood hazard areas shall be constructed per Figure 15.4.4. Piers shall be selected for the anticipated flood velocity at the installation site during the design flood.

**15.4.4.1** Piers shall be located per 6.2.5, except that piers supporting the homes' chassis shall not be spaced greater than 8 ft (2.44 m) apart.

**15.4.5 Footings.** Footings for flood velocities up to 2 ft/sec (0.61 m/sec) shall be precast or cast-in-place concrete. Footings for flood velocities over 2 ft/sec (0.61 m/sec) shall be cast-in-place with reinforcing steel that extends into the pier.

**15.4.5.1** Soil-bearing capacities listed in Table 6.3.3 shall be based on saturated soil conditions.

**15.5\* Prescriptive Foundation Wall Support and Anchorage Systems.** The provisions of Section 15.4 shall apply to support and anchorage systems using perimeter foundation walls, interior foundation shear walls, and interior piers.

**15.5.1 Specific Limitations — Foundation Wall Support and Anchorage Systems.**

**15.5.1.1** Manufactured homes shall be single units with a section width of 14 ft (4.27 m) or double units with a total width of 28 ft (8.53 m). Wood frame foundation walls shall comply with Figure 15.5.1.1(a). Concrete foundation walls shall comply with Figure 15.5.1.1(b).

**15.5.1.2** Single-unit widths up to 16 ft (4.88 m) shall be allowed, provided the connector spacing listed in Table 1 of Figure 15.5.1.1(a) and Table 1 of Figure 15.5.1.1(b) is reduced by the factor of the actual section width divided by 14.

**15.5.1.3** Manufactured homes shall be single or double units with roof slopes 4:12 or lower.

**15.5.2** Foundation walls shall be constructed using treated wood framing, reinforced masonry, or reinforced concrete.

**15.5.2.1** Wood framed foundation walls shall be constructed per Figure 15.5.2.1(a) and Figure 15.5.2.1(b).

**15.5.2.2** Reinforced masonry and reinforced concrete shall be constructed per Figure 15.5.2.2(a), Figure 15.5.2.2(b), and Figure 15.5.2.2(c).

**15.5.2.3** Concrete walls shall be reinforced as detailed for masonry.



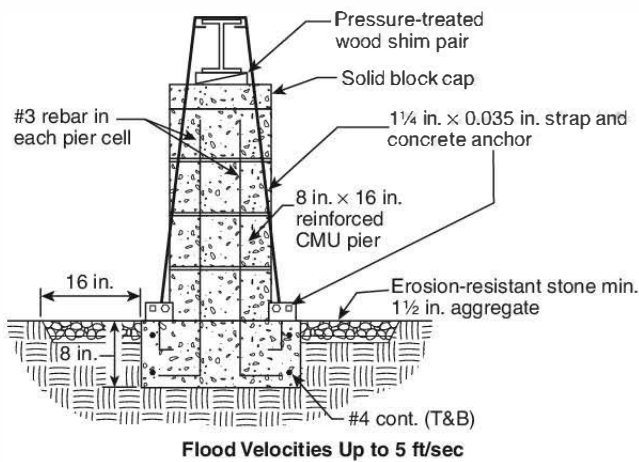
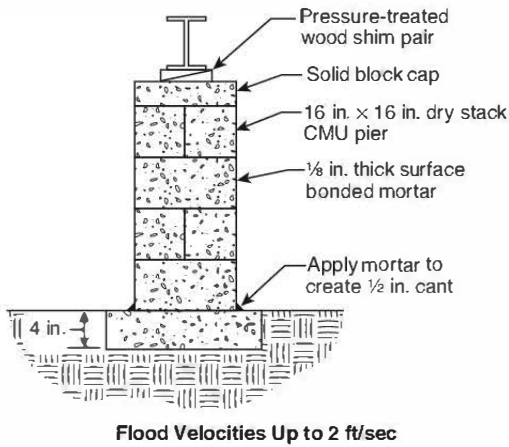
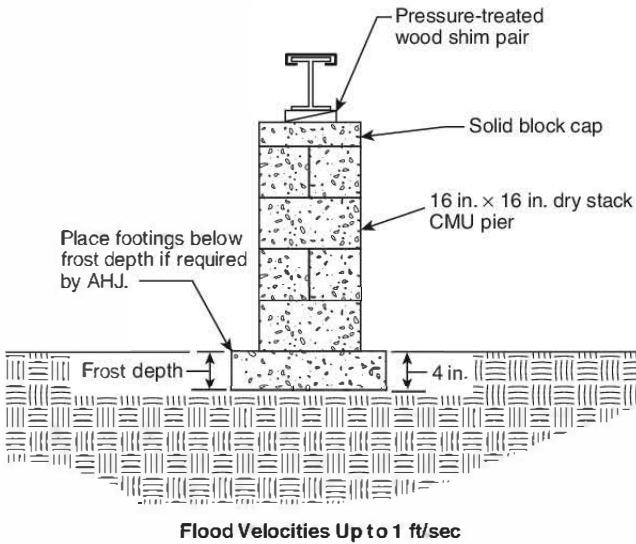

Note: For SI units, 1 in. = .0254 m, 1 ft = .3048 m, 1 ft/sec = .30 m/sec.

**FIGURE 15.4.4 Pier Construction Details.**

**15.5.3** Interior foundation shear walls for wood framed foundation walls shall be per Figure 15.5.3.

**15.5.3.1** Foundation shear walls shall be located beneath the manufacturer-designated shear walls contained in the manufactured home.

**15.5.3.2** When shear walls within the elevated unit are not designated by the manufacturer, foundation shear walls shall be located beneath interior walls that are parallel to end walls.

**15.5.4 Piers.**

**15.5.4.1** Piers for homes placed in flood hazard areas shall be constructed per Figure 15.5.1.1(a) and Figure 15.5.1.1(b).

**15.5.4.2** Piers shall be selected for the anticipated flood velocity at the installation site during a design flood.

**15.5.4.3** Piers shall be located per 6.2.5 except that piers supporting the homes' chassis shall not be spaced greater than 8 ft (2.44 m).

**15.5.5 Footings.** Footings for flood velocities up to 2 ft/sec (0.61 m/sec) shall be precast or cast-in-place concrete. Footings for flood velocities over 2 ft/sec (0.61 m/sec) shall be cast-in-place concrete with reinforcing steel that extends into the pier.

**15.5.5.1** Soil-bearing capacities (see Table 6.3.3) shall be based on saturated soil conditions.

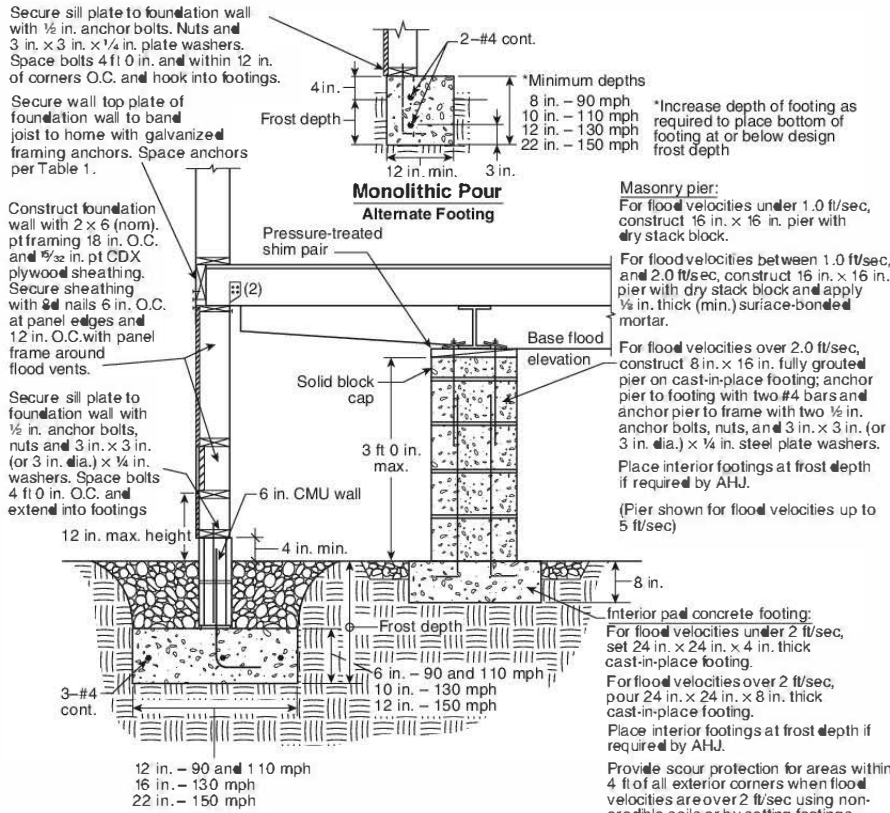

Note: For SI units, 1 in. = 0.0254 m, 1 ft = 0.3048 m, 1 mph = 1.61 km/hr, 1 lb = 0.45 kg.

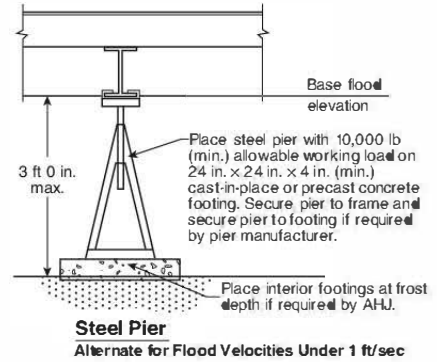

Table 1

| Floor framing connector schedule |                            |             |
|----------------------------------|----------------------------|-------------|
| Sidewalls                        | Framing connector spacing* |             |
| Wind speed                       | Single unit                | Double unit |
| 90 mph                           | 8 ft 0 in.                 | 8 ft 0 in.  |
| 110 mph                          | 8 ft 0 in.                 | 8 ft 0 in.  |
| 130 mph                          | 4 ft 0 in.                 | 4 ft 0 in.  |
| 150 mph                          | 4 ft 0 in.                 | 4 ft 0 in.  |
| End walls†                       |                            |             |
| Wind speed                       | Single unit                | Double unit |
| 90 mph                           | 4 ft 0 in.                 | 6 ft 0 in.  |
| 110 mph                          | 2 ft 6 in.                 | 5 ft 0 in.  |
| 130 mph                          | 6 ft 0 in.                 | 4 ft 0 in.  |
| 150 mph                          | 2 ft 4 in. (2)             | 2 ft 4 in.  |

\*Connector spacing is based on plate anchors capable of resisting (unfactored) 515# uplift and in-plane lateral loads and angle anchors, each capable of resisting (unfactored) 340# uplift loads. Locate plate and angle anchors within 1 ft 4 in. of sill plate anchor bolts.

†Connector spacing is based on plate anchors capable of resisting (unfactored) 515# in-plane lateral load and angle anchors capable of resisting (unfactored) 850# in-plane lateral loads.

FIGURE 15.5.1.1(a) Wood Framed Foundation Longitudinal Wall and Pier Details.

Secure 2 in. x 8 in. treated sill plate with 1/2 in. anchor bolts, nuts, and 3 in. x 3 in. (or 3 in. round) x 1/4 in. washers. Place anchor bolts 4 ft 0 in. (max.) on centers on side walls, within 1 ft 0 in. of corners and within 1 ft 0 in. of joints in sill plate sections. Secure band joist to sill plate with (1) galvanized steel framing plate and floor joists to sill with (2) galvanized steel framing angles. Space steel plates and angles per Table 1.

Construct bond beam with #4 continuous horizontal bar.

Construct foundation wall fully grouted with 8 in. CMU reinforced with #4 vert. bars centered on CMU cells placed 8 ft 0 in. O.C. (4 ft 0 in. for 110, 130, and 150 mph wind zones) within 12 in. of corners and openings. Extend bars into standard hooks in footings.

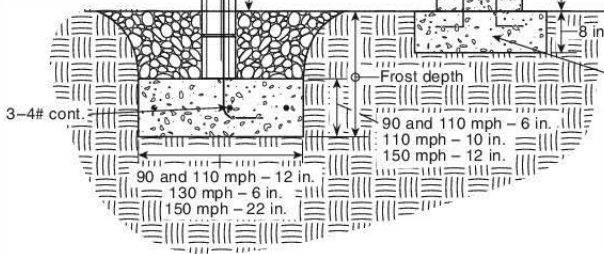

Note: For SI units, 1 in. = 0.0254 m, 1 ft = 0.3048 m, 1 mph = 1.61 km/hr, 1 lb = 0.45 kg.

16 in. x 8 in. masonry pier:  
For flood velocities under 1.0 ft/sec, dry stack block.

For flood velocities between 1.0 ft/sec and 2.0 ft/sec, dry stack block and apply 1/8 in. thick (min.) surface-bonded mortar.

For flood velocities over 2.0 ft/sec, construct fully grouted pier on cast-in-place footing; anchor pier to footing with two #4 bars and anchor pier to frame with two 1/2 in. anchor bolts, nuts, and 3 in. x 3 in. (or 3 in. dia.) x 1/4 in. steel plate washers.

Place interior footings at frost depth if required by AHJ.

Interior cast concrete footing:  
For flood velocities under 2.0 ft/sec, set 24 in. x 24 in. x 4 in. thick cast-in-place footing.

For flood velocities over 2.0 ft/sec, pour 24 in. x 24 in. x 8 in. thick cast-in-place footing. Place interior footings at or below frost depth if required by AHJ.

Provide scour protection for areas within 4 ft of all exterior corners when flood velocities are over 2.0 ft/sec, using non-erodible soils or by setting footings below max. scour depth for the flood velocities present.

Table 1

| Floor framing connector schedule |                            |             |
|----------------------------------|----------------------------|-------------|
| Side walls                       | Framing connector spacing* |             |
| Wind speed                       | Single unit                | Double unit |
| 90 mph                           | 8 ft 0 in.                 | 8 ft 0 in.  |
| 110 mph                          | 8 ft 0 in.                 | 8 ft 0 in.  |
| 130 mph                          | 4 ft 0 in.                 | 4 ft 0 in.  |
| 150 mph                          | 4 ft 0 in.                 | 4 ft 0 in.  |
| End walls†                       |                            |             |
| Wind speed                       | Single unit                | Double unit |
| 90 mph                           | 4 ft 0 in.                 | 6 ft 0 in.  |
| 110 mph                          | 2 ft 6 in.                 | 5 ft 0 in.  |
| 130 mph                          | 2 ft 0 in.                 | 4 ft 0 in.  |
| 150 mph                          | 2 ft 4 in. (2)             | 2 ft 4 in.  |

\*Connector spacing is based on plate anchors capable of resisting (unfactored) 515# uplift and in-plane lateral loads and angle anchors, each capable of resisting (unfactored) 340# uplift loads. Locate plate and angle anchors within 1 ft 4 in. of sill plate anchor bolts.

†Connector spacing is based on plate anchors capable of resisting (unfactored) 515# in-plane lateral load and angle anchors capable of resisting (unfactored) 850# in-plane lateral loads.

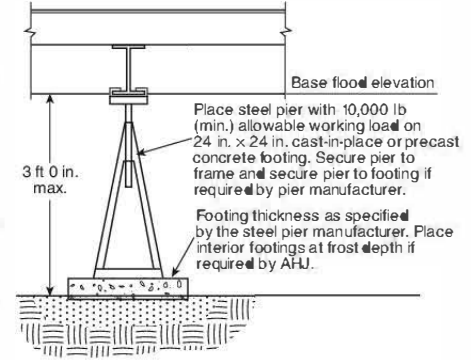

**Steel Pier**  
Alternate for Flood Velocities up to 1 ft/sec.

See pre-engineered foundation general notes for additional information, design criteria and limitations.

FIGURE 15.5.1.1(b) Masonry/Concrete Foundation Longitudinal Wall and Pier Details.

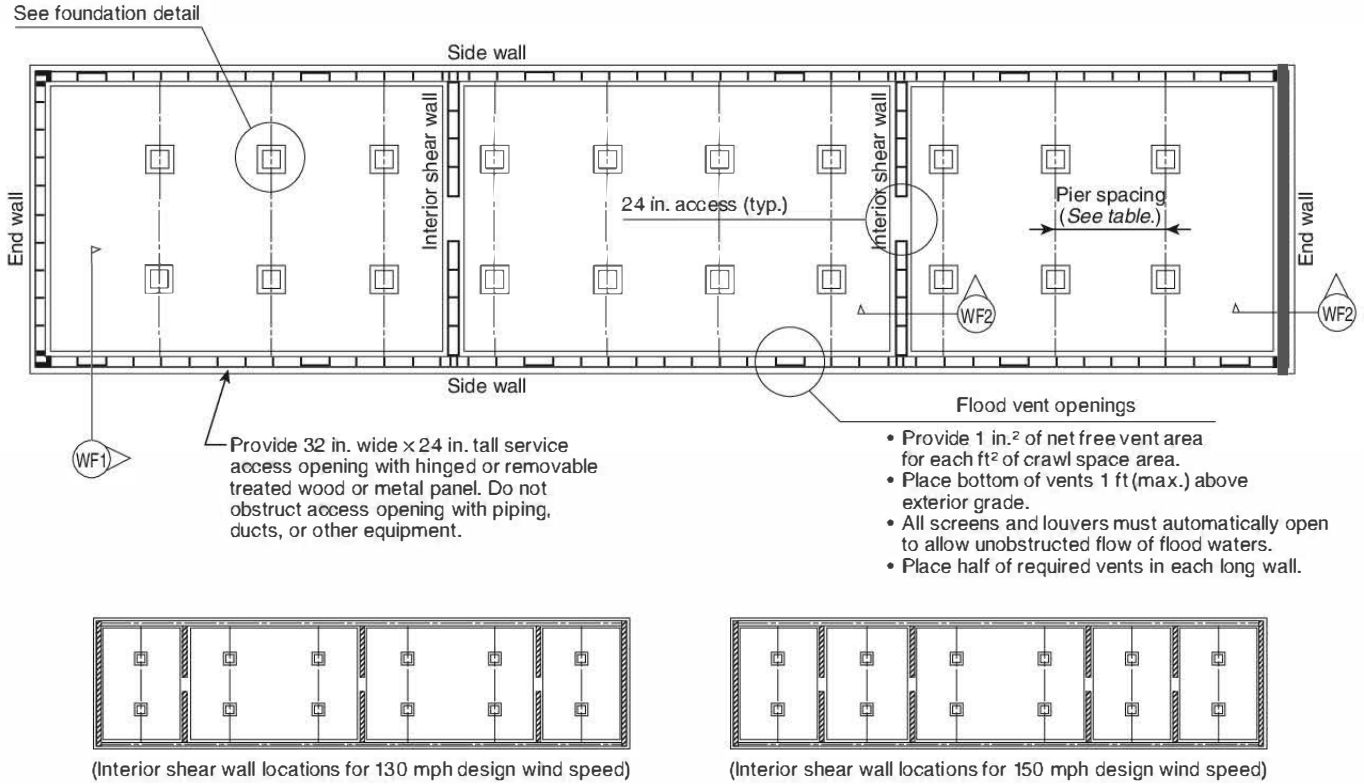

Note: For SI units, 1 in. = 0.0254 m, 1 ft = 0.3048 m, 1 mph = 1.61 km/hr, 1 in.<sup>2</sup> = 645 mm<sup>2</sup>, 1 ft<sup>2</sup> = 0.09 m<sup>2</sup>.

**FIGURE 15.5.2.1(a) Wood Framed Foundation Plan — Single Unit (Interior Shear Walls Shown for 90 mph and 110 mph Basic Wind Speeds).**

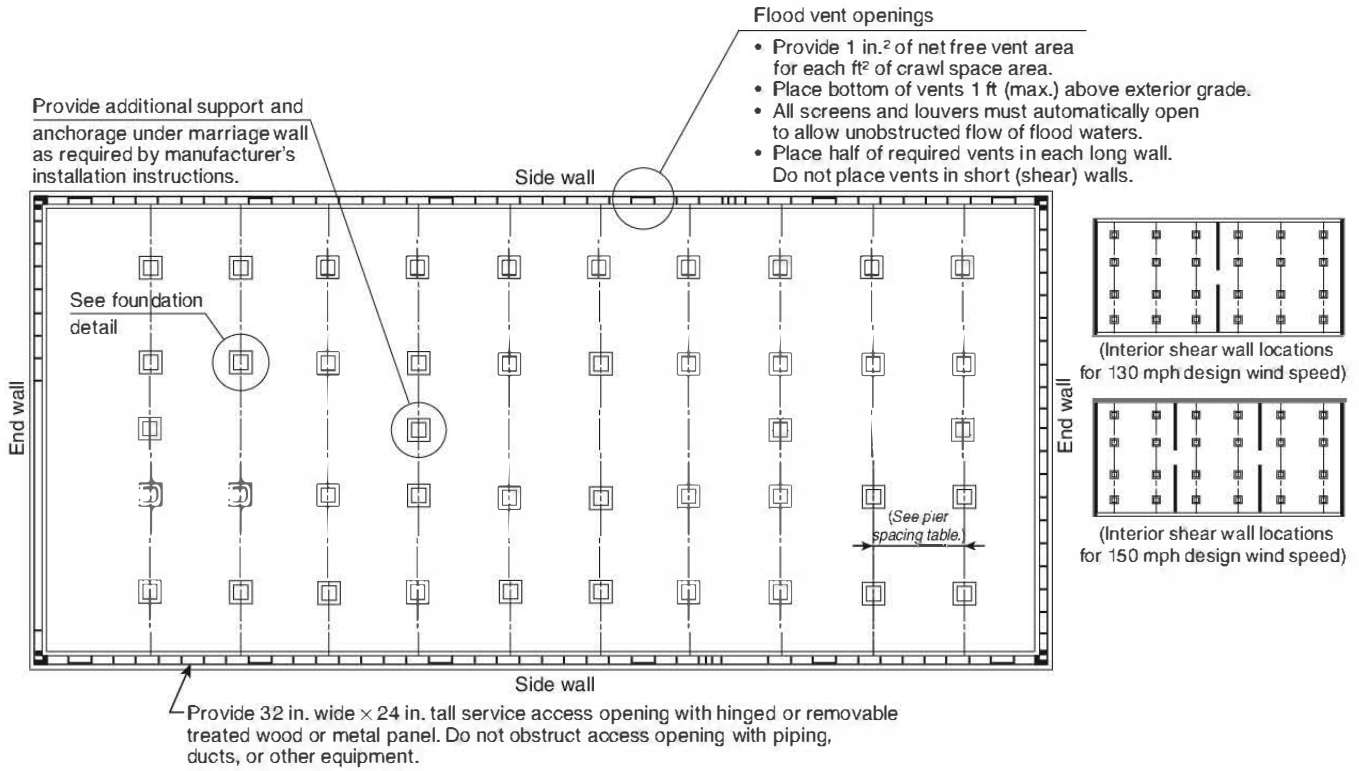

Note: 1 in. = .0254 m, 1 ft = 0.3048 m, 1 in.² = 645 mm², 1 ft² = 0.09 m², 1 mph = 1.61 km/hr.

**FIGURE 15.5.2.1(b) Wood Framed Foundation Plan — Double Unit (Interior Shear Walls Shown for 90 mph and 110 mph Basic Wind Speeds).**

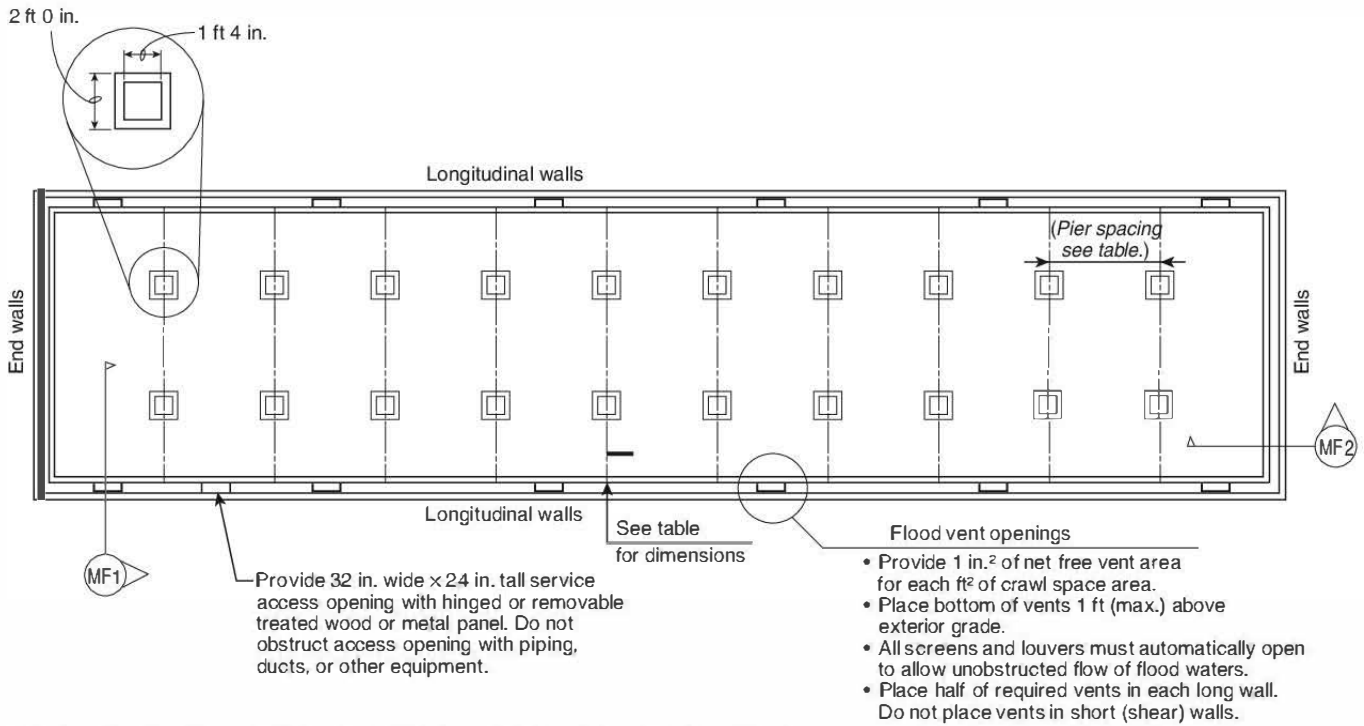

**FIGURE 15.5.2.2(a) Masonry/Concrete Foundation Plan — Single Unit.**

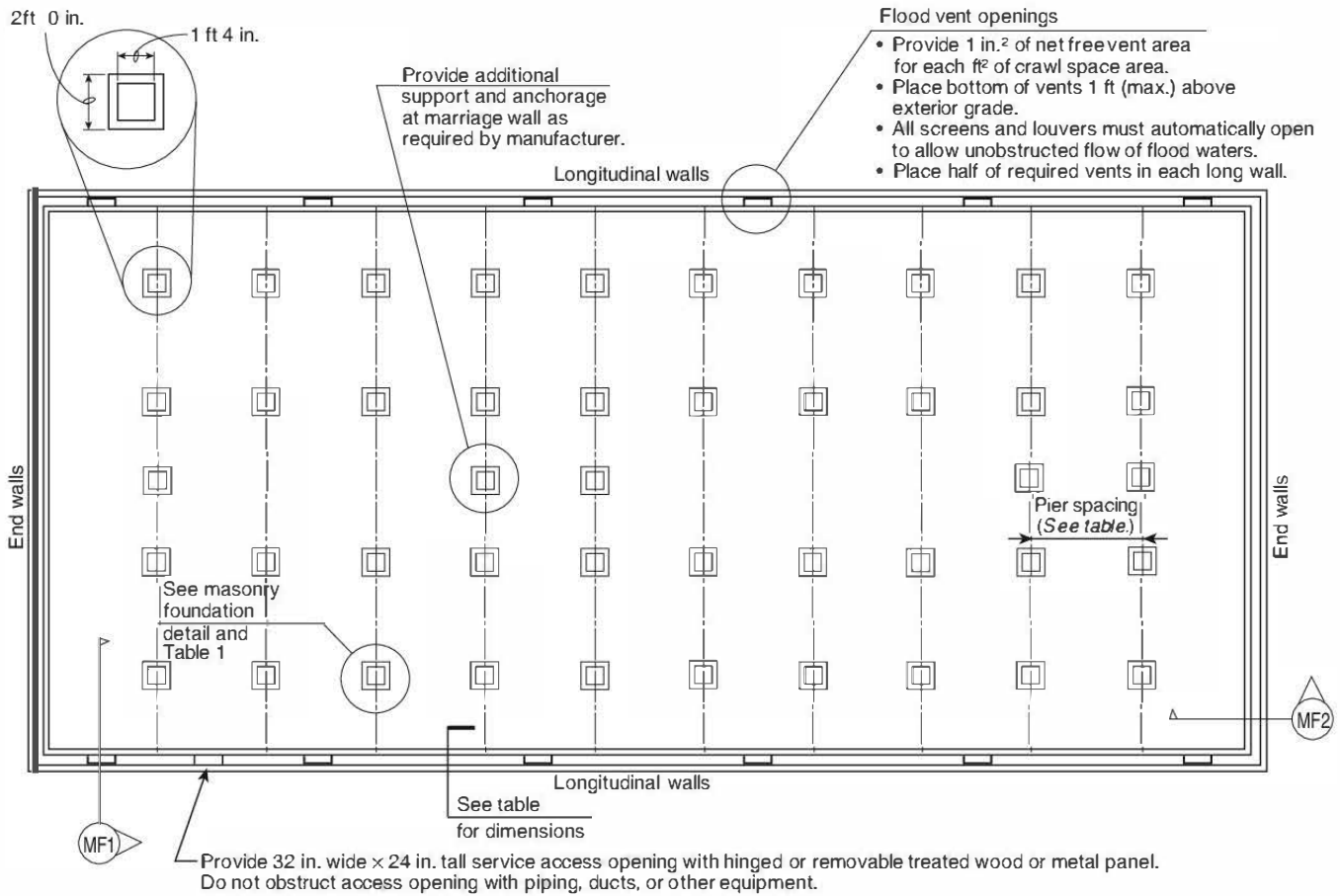

**FIGURE 15.5.2(b) Masonry/Concrete Foundation Plan — Double Unit.**

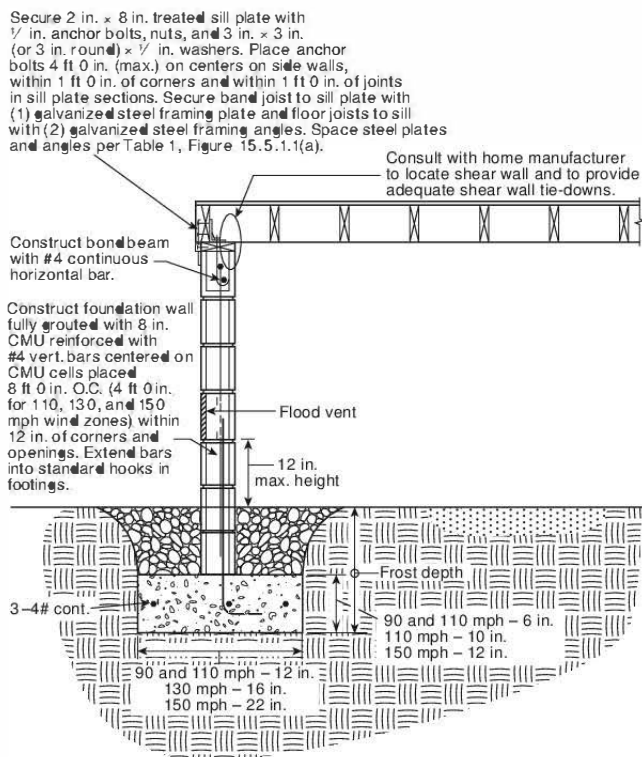

Note: For SI units, 1 in. = .0254 m, 1 ft = .3048 m, 1 mph = 1.61 km/hr.

**FIGURE 15.5.2(c) Masonry/Concrete Foundation End Wall Detail.**

### Annex A Explanatory Material

Annex A is not a part of the requirements of this NFPA document but is included for informational purposes only. This annex contains explanatory material, numbered to correspond with the applicable text paragraphs.

**A.1.1** Utilization of this standard by the homeowner and installation crew and use of a registered professional engineer in those unusual circumstances as required by this standard will help ensure the homeowner of a well-built, safe, and affordable home.

This standard contains instructions, including specifications and procedures, for installation of utility connections of a manufactured home. It has been written in an objective manner so that it can be understood by those who are trained in the installation of manufactured homes and who are properly licensed. It discusses the installation of the home from preparation of the site through final inspection. It includes many tables and figures giving important data for proper installation.

**A.1.3.3** The federal standards, regulations, and requirements for manufactured housing, as authorized by 42 USC 5401 et seq., are as follows:

- (1) 24 CFR 3280, "Manufactured Home Construction and Safety Standards"
- (2) 24 CFR 3282, "Manufactured Home Procedural and Enforcement Regulations"

**A.1.3.6.1** If a home site lies within a flood hazard area as shown on the AHJ's map, the map and supporting studies

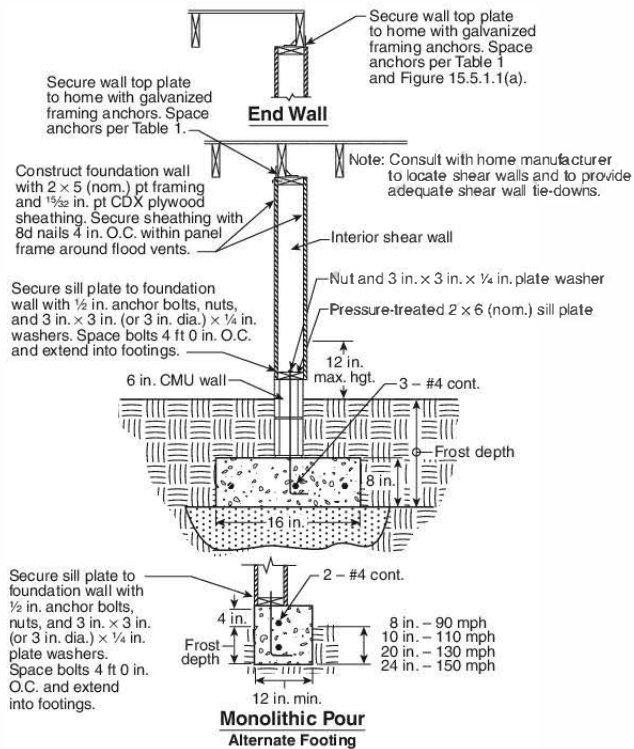

Notes:

- (1) For SI units, 1 in. = 0.0254 m, 1 mph = 1.61 km/hr.
- (2) Frame corners of foundation walls per Figure 3.8b of ANSI/AF&PA Wood Frame Construction Manual (WFCM), 2001.
- (3) Anchor the ends of all shear walls with connections with a working capacity of 1,950 lbs.\*

**FIGURE 15.5.3 Wood Framed Foundation End Wall and Interior Shear Wall Details.**

adopted by the AHJ shall be referenced to determine the flood hazard zone and design flood elevation at the site. Flood hazard maps adopted by the AHJ can include a flood insurance rate map (FIRM), flood boundary and floodway map (FBFM), or flood hazard boundary map (FHBM). The National Flood Insurance Program (NFIP) *Community Status Book* can be consulted to determine the date of the adopted map, and it is available at <http://www.fema.gov/fema/csb.shtm>. NFIP maps and studies can be viewed online at FEMA's Map Service Center (<http://store.msc.fema.gov>).

**A.3.2.1 Approved.** The National Fire Protection Association does not approve, inspect, or certify any installations, procedures, equipment, or materials; nor does it approve or evaluate testing laboratories. In determining the acceptability of installations, procedures, equipment, or materials, the authority having jurisdiction may base acceptance on compliance with NFPA or other appropriate standards. In the absence of such standards, said authority may require evidence of proper installation, procedure, or use. The authority having jurisdiction may also refer to the listings or labeling practices of an organization that is concerned with product evaluations and is thus in a position to determine compliance with appropriate standards for the current production of listed items.

**A.3.2.2 Authority Having Jurisdiction (AHJ).** The phrase "authority having jurisdiction," or its acronym AHJ, is used in NFPA documents in a broad manner, since jurisdictions and approval agencies vary, as do their responsibilities. Where public safety is primary, the authority having jurisdiction may



be a federal, state, local, or other regional department or individual such as a fire chief; fire marshal; chief of a fire prevention bureau, labor department, or health department; building official; electrical inspector; or others having statutory authority. For insurance purposes, an insurance inspection department, rating bureau, or other insurance company representative may be the authority having jurisdiction. In many circumstances, the property owner or his or her designated agent assumes the role of the authority having jurisdiction; at government installations, the commanding officer or departmental official may be the authority having jurisdiction.

**A.3.2.4 Listed.** The means for identifying listed equipment may vary for each organization concerned with product evaluation; some organizations do not recognize equipment as listed unless it is also labeled. The authority having jurisdiction should utilize the system employed by the listing organization to identify a listed product.

**A.3.3.6 Crossovers.** Crossover connections include heat ducting, electrical circuits, water pipes, drain plumbing, and gas lines.

**A.3.3.11 Flood Hazard Area.** Most communities will adopt the flood insurance rate map and designate the special flood hazard area as the area subject to floodplain management regulations. However, in some cases, a community will designate a larger area as being subject to floodplain management regulations. The term *flood hazard area* used in this standard includes both. The special flood hazard area is the area with a 1 percent or greater chance of flooding in any year and is commonly divided into V zones and A zones. V zones identify those coastal areas that are subject to damaging waves and erosion — they include zones V, VE, VO, and V1-30. A zones identify those areas that are subject to inundation by floodwaters but are not generally subject to waves and erosion — they include zones A, AE, AH, AO, AR, A99, and A1-30.

**A.3.3.14 Foundation Wall.** Types of foundation walls include but are not limited to concrete, concrete masonry, and pressure treated wood.

**A.3.3.19 Lowest Floor.** (See Figure A.3.3.19.) The lowest floor is used as a reference to determine how high a manufactured home must be elevated in a flood hazard area and is used to determine flood insurance premiums. In A zones, the lowest floor will be the bottom of the chassis frame beam, regardless of the foundation and support system used. In V zones, the lowest floor reference is the bottom of the lowest horizontal member, which will vary, depending on the foundation and support system used: it will be the bottom of the chassis frame beam, if the chassis frame beam is attached directly to piers or piles, or it will be the bottom of any horizontal structural beam or member that is attached to piers or piles and that directly supports the chassis frame beam.

**A.3.3.21 Manufactured Home Accessory Building or Structure.** Examples are awnings, garages, storage structures, carports, fences, windbreaks, or porches.

**A.3.3.25 Pier.** Types of piers include, but are not limited to, the following: (1) manufactured steel stands; (2) pressure-treated wood; (3) manufactured concrete stands; and (4) concrete blocks.

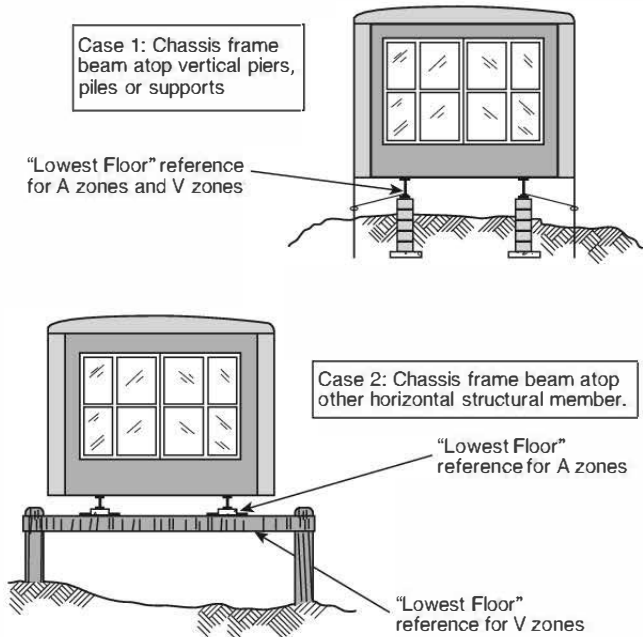

**FIGURE A.3.3.19** Lowest Floor Reference for A Zones and V Zones.

**A.4.2** Alterations can include such items as modifying the electrical, plumbing, or heating or cooling systems; adding a room, carport, or garage; or making major repairs such as replacing a roof.

**A.4.3** Each manufactured home bears a data plate affixed in a permanent manner near the electrical panel or other readily accessible and visible location. Data plates can be found in locations such as a master bedroom closet, a kitchen cabinet door, or under a sink. The data plate states the home's structural, roof load, thermal, and wind design. Specific information about the manufacturer, unit serial number, date of manufacture, and required information is included.

**A.5.6.1** Table 5.6.1 is an abridged extract from *NFPA 5000*, Table 36.3.4(a).

**A.5.7.2** Where the site is sloped toward the foundation, it is important to provide drainage swales on the uphill side of the home. Figure A.5.7.2 demonstrates the intent of this requirement.

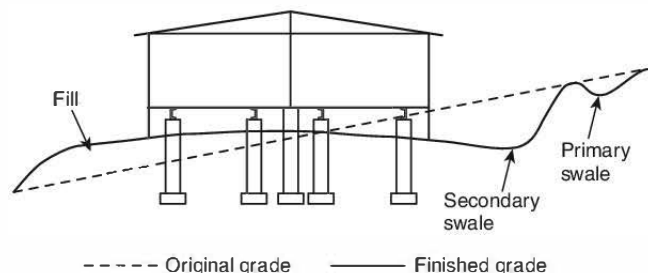

**FIGURE A.5.7.2** Sloped Site Construction.

**A.6.2.1** Section 6.2 does not consider uplift or lateral loads (*see Chapter 7*). The support system should resist vertical live and dead loads, including the weight of the home, its furnishings, and temporary roof loading, as well as resisting side loads imposed by wind forces to the foundation below. Consult the data plate for design data describing the roof and wind loads.

**A.6.2.2.1** Piers are permitted to be one of the following:

- (1) Hollow load-bearing concrete masonry blocks conforming to ASTM C90, *Standard Specification for Loadbearing Concrete Masonry Units*, Grade N, nominal 8 in. × 8 in. × 16 in (205 mm × 205 mm × 410 mm)
- (2) Commercial metal piers available in various heights and base widths listed and stamped with maximum load capacity

**A.6.2.3.2.1.1** Figure 6.2.2.1(a) and Figure 6.2.2.1(b) represent some of the typical design arrangements followed by several producers of manufactured homes. It should be noted that, in addition to design examples, guidance is found in these typical arrangements for drainage under the manufactured home, moisture prevention, consideration of termite infestation, and other critical aspects that must be taken into consideration when installing or setting up a manufactured home. The user should consult the producer or dealer of the manufactured home in question for the actual design configuration of support, piers, and so forth to be followed.

**A.6.2.4.1.5** Mortar will not normally be required. However, mortar, reinforcement, and filled cell masonry might be necessary for the piers to resist wind and flood loads.

**A.6.2.5.3** Supports might also be necessary for heavy concentrated loads such as heavy pieces of furniture (e.g., pianos, organs, waterbeds).

**A.6.2.5.4** See A.6.2.5.3.

**A.6.2.5.5** See A.6.2.5.3.

**A.6.3.2.3** Useful design guidelines can be found in the references found in Section E.2.

**A.6.3.3** Table 6.3.3 addresses only gravity forces.

**A.6.3.4** The benefits of footings are twofold: they can resist live and dead load forces in a downward direction to the soil below, and they can resist uplift forces by combining the weight of the pier, concrete, and the soil over the footing. Table 6.3.3 addresses only the download forces.

**A.7.1** The home weighs several tons. Temporary support blocking should be used to safeguard workers. During leveling, care should be taken to avoid stressing the home. Excessive and/or nonuniform jacking during the leveling process will cause the home to be racked and twisted and can result in damage to the home.

**A.7.2** To level the section, it is suggested that a water level be used to ensure all pier supports are at the same height before lowering the section to its final supported position. Figure A.7.2 shows one suggested method.

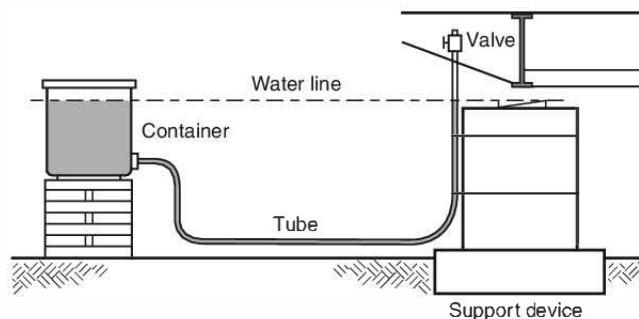

#### Material to make a water level:

- 5 gal pail with lid
- Plastic tubing — 100ft × 3/8 in. or 1/2 in.
- Cork — 1 1/2 in.
- Male barbed fitting — 3/8 in. × 3/4 in.
- Steel washer — 7/8 in.
- Nut — 3/4 in.
- Female barbed fitting — 3/8 in. × 1/2 in.
- Male valve — 1/2 in.
- Pipe sealant
- Food coloring — 8 oz

#### How to use a water level:

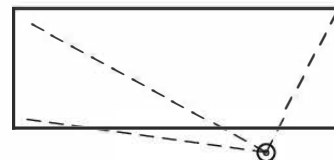

Place at any point around home:

Unroll tubing: Position level where it is to be used. Take care not to have kinks in the tubing, step on it, or lay anything on it.

Check for air bubbles: To remove any, lower valve below bottom of container and open. Close valve when bubbles are out.

Container location: Locate container so valve can reach all areas of the home. Build up container so water line in valve end of tubing is at the predetermined height support at which devices will be set.

Leveling of support device: Secure valve above determined height and open. Adjust device as needed. Close valve and move to next support device.

Level all support devices before lowering home.

Note: For SI units, 1 in. = 25.4 mm.

**FIGURE A.7.2** Leveling Section with Water Level.

**A.7.3** The following steps are one method of interconnecting multisection homes when the manufacturer's installation instructions are not available:

- (1) Provide an air infiltration barrier on the mating edges of the floor, end walls, and ceilings.
- (2) Contact the home manufacturer or obtain the manufacturer's installation instructions for joining the transportable sections. If the original manufacturer's method of roof and marriage wall closure cannot be determined by examination, such as factory drilled bolt holes or roof lag bolts, then close the roof with 30 gauge  $\times$  9 in. (230 mm) wide galvanized steel cap continuing for the length of the home. Fasten this cap with #10 screws or 1 in.  $\times$  1¼ in. (25 mm  $\times$  32 mm), 16 gauge staples, 6 in. (150 mm) on center each side. Secure end walls and any marriage wall openings with #10  $\times$  6 in. wood screws, at a minimum of 6 in. on center staggered intervals. Fasten the floor with ¾ in.  $\times$  6 in. (9.5 mm  $\times$  150 mm) lag screws installed at a maximum of 36 in. (915 mm) on center staggered and at a 45-degree angle. Predrill pilot holes for lag screws with a ¼ in. (6.4 mm) drill (maximum) before installing lag screws.

**A.7.5.2** Section 7.5 summarizes and defines the types of normal installations. The pier-and-ground-anchor system, as provided in this standard, is the most common.

The following are types of foundation systems:

- (1) *Piers and anchors.* The manufactured home rests on piers of concrete block, formed-in-place concrete, permanent wood, or steel pedestals on permanent wood, crushed stone, or concrete footers. The ground anchors in the soil are angled to resist straps or embedded in deadmen in the soil. Straps are tied to the frame, with or without over-the-top straps.
- (2) *Concrete slab or continuous footings.* The manufactured home rests on a concrete slab or ribbons of concrete. The straps are tied between the frame and the perimeter footers or concrete slab.
- (3) *Pile/post system.* The manufactured home rests on piles or posts placed sufficiently deep in the ground to resist all wind, snow, and earthquake forces. Straps fasten the home to the piles or posts or to caps placed thereon.
- (4) *Concrete, concrete block, or wood foundation, load-bearing, perimeter walls.* The manufactured home rests on exterior load-bearing walls that sit on concrete or gravel footings. Straps fasten the home to the walls to resist all external forces.

**A.7.5.4.2** Design guidelines can be found in HUD Handbook 4930.3G, *Permanent Foundations Guide for Manufactured Housing* (see E.2.1).

**A.7.7.1.1** Failure to remove the sheeting can cause condensation to build up in the walls and damage the home.

**A.7.7.2** The exterior siding on the front and rear end walls and exposed mating line walls (multisection) might have been shipped loose by the manufacturing facility with the home. The vapor retarder and/or insulation are installed by the home's manufacturing facility.

**A.7.7.4.2** Entry of outside air into the home's floor cavity is one of the most frequent causes of water piping freeze-up. Necessary repairs should be completed regardless of whether skirting is to be installed around the perimeter of the home.

**A.8.2** Because hinged roofs, eaves, and vent stacks are usually very heavy, special care must be taken when installing them to avoid personal injury and to avoid structural damage.

**A.8.6** For an example of the ventilation options, see Figure A.8.6.

**A.8.8.1** Homes with open slatted decking at recessed entries, with open porches, or with decks with skirting in front of, behind, or under the deck-home transition must have adequate drainage to prevent water from draining back under the home.

**A.8.8.2.1** Where local codes have minimum ventilation requirements for crawl spaces, the requirements of 8.8.2.1 through 8.8.2.3 apply to homes with skirting and continuous foundations.

**A.8.9** Careless installation of telephone and cable television lines can be hazardous. Failure to follow instructions can result in serious personal injury or death. The walls and floors of the home contain electrical circuits, plumbing, and ductwork. Avoid contact with these systems when drilling through and placing cables within these cavities. Only trained professionals should handle such work.

**A.9.1** IMPORTANT: Do not let the exhaust system end under the home, where excess moisture or flammable material can accumulate. (Follow the dryer manufacturer's instructions for installing the exhaust system.)

**A.9.2** IMPORTANT: Before installing a comfort cooling system, check the home's data plate to ascertain that the home has been designed for the installation of central air conditioning. Only qualified personnel can install a comfort cooling system not provided with the home. Follow the product manufacturer's installation instructions and conform to all local codes.

**A.9.2.1.1** CAUTION: Oversized air conditioning equipment can lead to poor overall performance of the home's cooling system. Do not cut any floor framing when installing return air grille(s).

**A.9.2.1.2** IMPORTANT: Electrical circuits within the home might not have been sized for the additional load of non-factory installed air conditioning, and a separate, outside electrical supply might have to be provided.

**A.9.3.5** If there are obstructions on the site that extend higher than the home's roof peak and are within 10 ft (3050 mm) of the chimney, the installer might have to provide an additional section of chimney pipe, if required to do so by the authority having jurisdiction.

**A.9.3.7** If the added ducts are not supplied, they can be purchased at a hardware store. The fireplace manufacturer's instructions for installing combustion air ducts can be found in the fireplace/stove or with the chimney parts.

**A.10.2.3.2** Figure A.10.2.3.2 illustrates the intent of this paragraph.

**A.10.4.2** IMPORTANT: Special orifices and regulators are required for specific gases. See the instructions accompanying each gas-burning appliance for modification instructions. Special attention should be given to homes sited at altitudes above 3000 ft (945 m).

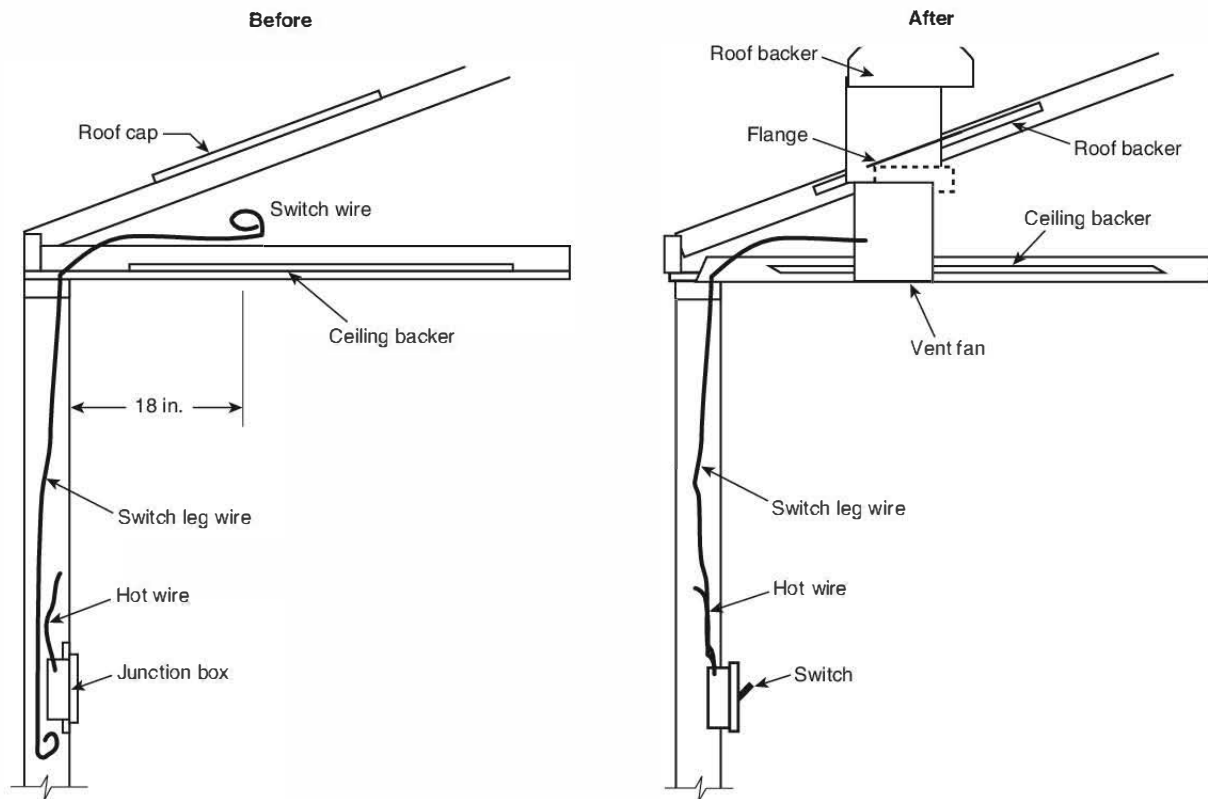

Note: For SI units, 1 in. = 25.4 mm.

**FIGURE A.8.6 Ventilation Improvement Installation.**

**A.10.4.3** To operate gas-burning appliances safely and efficiently, do not exceed the design pressure limitations. For natural gas systems, the incoming gas pressure should remain between 6 in. and 8 in. of water column (1.5 kPa and 2 kPa). For LP-Gas systems, the pressure should register between 12 in. and 14 in. of water column (3 kPa and 3.5 kPa).

**A.10.4.4** A gas crossover might need to be installed in multi-section homes.

**A.10.4.6 IMPORTANT:** Have the gas system connected to the gas supply by a qualified service person who is familiar with local codes and who is licensed where required, or by a representative of the gas company.

**IMPORTANT:** Have the gas supply turned on by a qualified service person who is familiar with local codes and who is licensed where required, or by an authorized representative of the gas company.

**A.10.4.7.1 IMPORTANT:** Ensure that the water heater is filled with water before lighting the pilot light.

**A.10.6** An inadequate power supply can result in improper operation of, and possible damage to, motors and appliances. The current rating in amperes of the home can be found on the tag located outside, next to the feeder or service entrance and on the electrical distribution panel.

**A.10.6.1 IMPORTANT:** Proper and safe connection depends on the type of supply system with which the home is equipped.

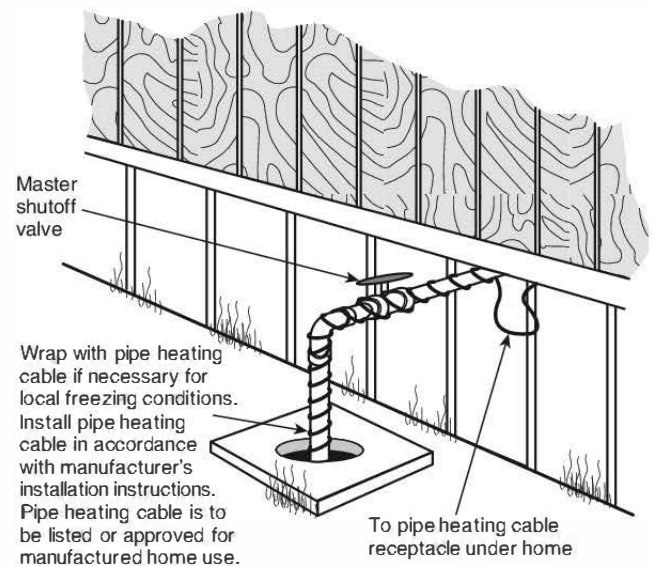

**FIGURE A.10.2.3.2 Typical Water Connection.**

**A.12.1** The installer is referred to Federal Regulations governing development in floodplains in 44 CFR 60.3, and to the commentary Section C.5.3 of ASCE/SEI 7, *Minimum Design Loads for Buildings and Other Structures*.

**A.12.1.1.2** Flood damage-resistant materials are those that can withstand direct contact with flood waters for at least 72 hours without sustaining significant damage. Significant damage means any damage greater than that requiring cosmetic repair (e.g., repainting). NFIP Technical Bulletin 2, *Flood Damage-Resistant Materials Requirements for Buildings Located in Special Flood Hazard Areas*, <http://www.fema.gov/plan/prevent/floodplain/techbul.shtm>, provides additional information on flood damage-resistant materials. Note that this provision is intended to apply to all installation components except skirting that does not provide structural support to the home or its foundation and crossover ductwork below the bottom of the chassis frame beam.

**A.12.1.1.3** This provision does not require a permanent foundation for all manufactured homes. This provision does not consider deflection of ground anchors and/or the support system, within the limits established by the AHJ as being acceptable, to be permanent lateral movement.

**A.12.1.2** The Federal Emergency Management Agency (FEMA) publication FEMA P-85, *Protecting Manufactured Homes from Floods and Other Hazards*, contains design and construction recommendations for elevated foundations as well as for connections and anchoring systems that will allow the foundation system to resist flood forces.

**A.12.2.2** This provision is commonly referred to as the “36 inch rule” or “3 foot rule,” which pertains to home parks that predate the jurisdiction’s first adoption of a flood hazard ordinance or map (these parks are referred to as “existing” home parks). In such instances, home installations and substantial improvements are permitted with the lowest floor below the design flood elevation (where the design flood elevation is greater than 36 in. above grade), unless a home on that site has been substantially damaged by flood. If a home has been substantially damaged by flood, any repaired, new, or replacement home on that site must comply with the requirements for new installations outside existing home parks.

Installations in the following instances are not permitted to take advantage of the 36 in. rule:

- (1) Substantially damaged homes and replacement homes for substantially damaged homes
- (2) Home installations in expansions to existing manufactured home parks (where the expansion does not predate the jurisdiction’s first adoption of a flood hazard ordinance or map)
- (3) Home installations in new manufactured home parks (where the park does not predate the jurisdiction’s first adoption of a flood hazard ordinance or map)

- (4) Home installations outside existing manufactured home parks

**A.12.5.2** FEMA Form 81-31, *National Flood Insurance Program Elevation Certificate and Instructions*, which can be used to submit surveyed elevation information, is available online at <http://www.fema.gov/nfip/elvinst.shtm>. This form is also used by insurance agents to obtain the correct insurance rating.

**A.12.7.2** This provision requires the same level of flood resistance for utilities and equipment as for the home itself. Utilities and equipment can be elevated or can be installed such that they resist flood loads and flood damage. However, this standard considers crossover ductwork to be expendable, inexpensive, and easily replaced, and allows its placement below the chassis frame beam (*see exception*). More information on utility installation in flood hazard areas can be found in FEMA P-348, *Protecting Building Utilities from Flood Damage*.

**A.15.1** Foundation designs contained herein are based on specific flood velocity ranges. The AHJ can rely on historical evidence or hydraulic calculations to determine flood velocities and the appropriate foundation design.

**A.15.3.1** The prescriptive designs should not be used for homes that take advantage of the “3 foot rule” provision discussed in A.12.2.2.

**A.15.5** The anchorage requirement is based on a shear load of 490 lb/lf times a 4 ft tall foundation wall height. The 490 lb/lf shear load is per Table 3.17.D of ANSI/AWC *Wood Framed Construction Manual (WFCM) for One- and Two-Family Dwellings*, and applies to 1/2 in. (or thicker) structural sheathing blocked and nailed along all edges with 8d nails 4 in. on center. Framing corners per Figure 3.8b of ANSI/AWC *WFCM* allows one shear wall anchor to anchor perpendicular shear walls.

## Annex B Final Inspection Checklist

*This annex is not a part of the requirements of this NFPA document but is included for informational purposes only.*

**B.1** Final inspection should be made when the home installation (setup) is complete. A checklist like the one in Figure B.1 should be developed to ensure that no items have been overlooked and that work has been properly completed.

**B.2** All transit and installation damage is required to be reported to the manufacturer if the home is a new unit. Check with local authorities having jurisdiction prior to installation for code requirements and permits/inspections required.

## Annex C Sample Checklist for AHJ Officials

*This annex is not a part of the requirements of this NFPA document but is included for informational purposes only.*

**C.1** Figure C.1 is a sample form that can be used as a checklist by the AHJ for the installation of manufactured homes.

## CHECKLIST FOR FINAL INSPECTION UPON COMPLETION OF HOME INSTALLATION

### 1. *Water and drain systems.* Check to ensure the following:

- Correct materials for water and drain lines have been used
- Connections and splices are properly made
- Supports are of correct material and are properly spaced
- Necessary inspections and tests have been made
- Water lines are protected from freezing, when applicable
- Proper slope has been maintained on drain lines

### 2. *Electrical systems.* Check to ensure the following:

- Panel amperage matches connection to home
- Electrical inspections have been performed, connections between multisections are in accordance with the MHCSS, and access covers are in place

### 3. *Gas/fuel oil systems.* Check to ensure the following:

- Correct materials and fittings are used
- The pressure test has been conducted on the gas system
- The connection between multisections are in accordance with the MHCSS, with access as required

### 4. *Appliance function, operation, and venting.* Check to ensure the following:

- Vent or chimney extensions shipped loose on the home have been mounted and serviced in accordance with the manufacturer's instructions
- Appliances and valves have been tested and are properly working
- Venting of appliances under unit are in accordance with the MHCSS
- Dryer is properly vented
- Solid-fuel-burning fresh air intake is properly installed
- Temporary shipping blocks have been removed
- Exhaust fan operation and air flow are correct

### 5. *Windows and doors.* Check to ensure the following:

- Windows meet egress requirements and have operation instructions on them
- Doors function properly
- Temporary shipping hardware has been removed from windows and doors

### 6. *Exterior of home.* Check the following:

- For damage to undercarriage or bottom board
- Chassis, floor joists, or both for installation/transportation damage
- Bottom board for rips or tears
- For damage to siding (cracks, breaks, holes, nail pops, etc.)

For damage to metal or composition roofs, such as the following:

- Holes or rips in metal roof
- Shingles for damage and sealing
- Drip edge or fascia damage
- Roof openings for sealing (vents, stacks, etc.)
- To ensure that when gutters and downspouts are installed, the water is diverted away from the home

### 7. *Interior of home.* Check the following:

- For damage to floor coverings (vinyl, carpet)
- For damage to wall finish (holes, cracks, nail pops, etc.)
- For damage to ceiling finish (holes, cracks, nail pops, etc.)
- For damage to interior trim (splints, cracks, nail pops, etc.)
- Multisection common areas for correct finishing

### 8. *Skirting.* Check to ensure the following:

- Skirting used is in accordance with owner's specifications
- Venting is in accordance with the manufacturer's specifications
- Skirting is constructed to prevent frost movement in areas where it occurs
- Polyethylene ground cover is correctly installed

### 9. *Blocking/footings.* Check to ensure the following:

- Footings are of proper size and construction for soil conditions
- Spacing of piers is in accordance with the manufacturer's guidelines
- Footing depth is below frost line
- Foundation walls, if required, meet local codes, ordinances, or covenants
- Pier construction meets manufacturer's specifications

### 10. *Anchoring.* Check to ensure the following:

- Approved anchors are used
- Correct number of anchors, straps, or both are used according to the manufacturer's instructions
- Anchors are installed at correct angles and in accordance with the anchor manufacturer's listing for approval

### 11. *Miscellaneous.* Check to ensure the following:

- The smoke alarms or smoke detectors are installed per NFPA 501
- The smoke alarms or smoke detectors are inspected and tested in accordance with the smoke alarm or smoke detector manufacturer's instructions
- Construction seals (the "HUD" label) have not been damaged, removed, or covered by skirting
- Installation/anchoring certificates, seals, or both have been issued and installed, if required
- Data plate is intact and legible
- Low-hanging tree branches and bushes have been trimmed

FIGURE B.1 Sample Final Inspection Checklist.

### CHECKLIST FOR THE AUTHORITY HAVING JURISDICTION

Owner: \_\_\_\_\_

Address: \_\_\_\_\_

Manufacturer: \_\_\_\_\_

Address: \_\_\_\_\_

Model: \_\_\_\_\_ Serial Number: \_\_\_\_\_ Mfd. Date: \_\_\_\_\_

"HUD" Label/State Label Number: \_\_\_\_\_

Dealer: \_\_\_\_\_ Dealer #: \_\_\_\_\_

Installer: \_\_\_\_\_ Installer #: \_\_\_\_\_

Local Authority Having Jurisdiction Inspection: \_\_\_\_\_

Local Permits: \_\_\_\_\_

#### INSTALLATION:

Installation #: \_\_\_\_\_ Anchor #: \_\_\_\_\_

Instructions Used: Manufacturer: \_\_\_\_\_ State: \_\_\_\_\_

Foundation: Foundation to Local Building Code: \_\_\_\_\_

Support: Support Locations per Manufacturer or Engineered Design: \_\_\_\_\_

Elevation: Elevation of Lowest Floor (If in a Flood Hazard Area): \_\_\_\_\_

Support Footings: Type: \_\_\_\_\_

Size: \_\_\_\_\_

Piers: Materials: \_\_\_\_\_

Spacing: \_\_\_\_\_

Shims: \_\_\_\_\_

Lot/Soil Conditions: \_\_\_\_\_

Anchor: Spacing: \_\_\_\_\_

Equipment Used: \_\_\_\_\_

Equipment Approved: \_\_\_\_\_

Frame Removed: Permitted by Manufacturer: \_\_\_\_\_

(Prior to 11/89)

Foundation to Local Building Code: \_\_\_\_\_

Support Locations per Manufacturer or Engineered Design: \_\_\_\_\_

Elevation of Lowest Floor (If in a Flood Hazard Area): \_\_\_\_\_

Skirting: Type: \_\_\_\_\_

Attachment to Home: \_\_\_\_\_

Poly on Grade: \_\_\_\_\_

Access Panel: \_\_\_\_\_

#### UTILITIES:

Water: Correct Materials/Fittings: \_\_\_\_\_

Protected from Freezing: \_\_\_\_\_

Support Spacing: \_\_\_\_\_

**FIGURE C.1 Sample Checklist for Enforcement Officials.**

**CHECKLIST FOR THE AUTHORITY HAVING JURISDICTION (Cont.)**

Waste: Correct Materials/Fittings: \_\_\_\_\_  
 Slope to Drain: \_\_\_\_\_  
 Support Spacing: \_\_\_\_\_  
 Main Sewer Connection (Gasketed): \_\_\_\_\_

Gas: Correct Materials/Fittings: \_\_\_\_\_  
 Pressure Test: \_\_\_\_\_

Electric: Connection Between Halves (MHCSS — “HUD-Code”): \_\_\_\_\_

(“Pre-HUD-Code” Homes only)

Aluminum Wiring: \_\_\_\_\_  
 Method Used to Eliminate or Reduce Danger: \_\_\_\_\_  
 Supply Amps (Matches Panel in Home): \_\_\_\_\_

Smoke Alarms or  
 Smoke Detectors: Installed: \_\_\_\_\_  
 Alterations: \_\_\_\_\_  
 Inspected/Functionally Tested: \_\_\_\_\_

**DATA PLATE:**

Roof Zone Load: \_\_\_\_\_ Heating Zone: \_\_\_\_\_  
 Furnace: Original:  yes  no Gypsum Board Lined: \_\_\_\_\_  
 Water Heater: Original:  yes  no Gypsum Board Lined: \_\_\_\_\_  
 Dryer: Original:  yes  no  
 Range: Original:  yes  no

**MISCELLANEOUS:**

Fireplace:  yes  no Model: \_\_\_\_\_ Approved: \_\_\_\_\_  
 Chimney: \_\_\_\_\_ Fresh Air Intake: \_\_\_\_\_

Venting: Skirting/Foundation: \_\_\_\_\_  
 Roof and/or O.H.s: \_\_\_\_\_  
 Alterations: Approved: \_\_\_\_\_ Inspected: \_\_\_\_\_

Comments: \_\_\_\_\_  
 \_\_\_\_\_  
 \_\_\_\_\_  
 \_\_\_\_\_  
 \_\_\_\_\_

Inspector: \_\_\_\_\_ Date: \_\_\_\_\_ Time: \_\_\_\_\_

Present During Inspection: \_\_\_\_\_

**FIGURE C.1** *Continued*



## Annex D Sample Schedule for Manufactured Home Installation Permits

*This annex is not a part of the requirements of this NFPA document but is included for informational purposes only.*

**D.1** For installation of new or relocated homes in a municipality, a basic permit flat fee can be established by the AHJ to cover the following inspections:

- (1) Foundation inspection
  - (a) Frost depth foundation (requires extra inspection)
  - (b) Piers and footings on grade (common to most community installations)
  - (c) Skirting installation/ventilation
  - (d) Anchoring of unit (when required by the AHJ or by manufacturer's instructions)
- (2) Plumbing inspection
  - (a) Sewer connection
  - (b) Water connection
  - (c) On-site work performed on home water/drain lines
- (3) Gas-line inspection
  - (a) Materials and connections
  - (b) Testing
- (4) Structural inspection
  - (a) Data plate information (on homes manufactured June 15, 1976 and later)
  - (b) Structural damage
  - (c) Precode upgrading rules by the AHJ (*see Annex C*)
- (5) Electrical inspection (state electrical board or municipality)

**D.2** Separate permit or hourly inspection fees in excess of the original basic permit flat fees can be established by the AHJ for the following:

- (1) Required corrections — reinspection
- (2) Accessory structures or buildings
- (3) Inspection (e.g., wood decks, carports, entryways, out-buildings)
- (4) Alterations to original home inspection (i.e., structural, mechanical, plumbing, electrical) — contact the AHJ prior to issuance, as submittal to the AHJ might be required for approval
- (5) Plan review of accessory structures or alterations

## Annex E Informational References

**E.1 Referenced Publications.** The documents or portions thereof listed in this annex are referenced within the informational sections of this standard and are not part of the requirements of this document unless also listed in Chapter 2 for other reasons.

**E.1.1 NFPA Publications.** National Fire Protection Association, 1 Batterymarch Park, Quincy, MA 02169-7471.

NFPA 501, *Standard on Manufactured Housing*, 2021 edition.

NFPA 5000®, *Building Construction and Safety Code*®, 2021 edition.

## E.1.2 Other Publications.

**E.1.2.1 ASCE Publications.** American Society of Civil Engineers, 1801 Alexander Bell Drive, Reston, VA 20191-4400.

ASCE/SEI 7, *Minimum Design Loads for Buildings and Other Structures*, 2005.

**E.1.2.2 ASTM Publications.** ASTM International, 100 Barr Harbor Drive, P.O. Box C700, West Conshohocken, PA 19428-2959.

ASTM C90, *Standard Specification for Loadbearing Concrete Masonry Units*, 2016a.

**E.1.2.3 AWC Publications.** American Wood Council (AWC), 222 Catoctin Circle, SE, Suite 201, Leesburg, VA 20175.

ANSI AWC WFCM, *Wood Frame Construction Manual (WFCM) for One- and Two-Family Dwellings*, 2015.

**E.1.2.4 FEMA Publications.** Federal Emergency Management Agency, Washington, DC 20472.

FEMA P-85, *Protecting Manufactured Homes from Floods and Other Hazards*, November 2009.

FEMA P-348, *Protecting Building Utilities from Flood Damage*, November 1999.

FEMA Form 81-31, *National Flood Insurance Program Elevation Certificate and Instructions*, 2009.

**E.1.2.5 NFIP Publications.** FEMA National Flood Insurance Program, 500 C Street, SW, Washington, DC 20472.

*Community Status Book.*

Technical Bulletin 2, *Flood Damage-Resistant Materials Requirements for Buildings Located in Special Flood Hazard Areas*, August 2008.

**E.1.2.6 U.S. Government Publications.** U.S. Government Publishing Office, 732 North Capitol Street, NW, Washington, DC 20401-0001.

HU Handbook 4930.3G, *Permanent Foundations Guide for Manufactured Housing*.

Title 24, Code of Federal Regulations, Part 3280, "Manufactured Home Construction and Safety Standards (MHCSS)."

Title 24, Code of Federal Regulations, Part 3282, "Manufactured Home Procedural and Enforcement Regulations."

Title 42, United States Code, Part 5401, "The Public Health and Welfare."

Title 44, Code of Federal Regulations, Part 60.3, "Flood Plain Management Criteria for Flood-Prone Areas."

**E.2 Informational References.** The following documents or portions thereof are listed here as informational resources only. They are not a part of the requirements of this document.

**E.2.1 Foundation-Related References.** The following references are being provided to assist the user in obtaining related information pertaining to foundations.

*Building Foundation Design Guidebook*, Doc. No. DE88013350, National Technical Information Service, 5301 Shawnee Road, Alexandria, VA 22312.

*Design Guide for Frost-Protected Shallow Foundations*, NAHB Research Center, Upper Marlboro, MD, June 1994.

*Energy Efficient Frost Protected Shallow Foundation Design Guidelines*, 1999 NAHB Research Center.

*Guidelines for Anchor System Design — Technical Support Document*, Manufactured Housing Research Alliance, 2109 Broadway, Suite #203, New York, NY 10023, January 2000.

*Manufactured Home Foundation Design for Seasonally Frozen Ground*, Progressive Engineering Incorporated, 58640 State Road 15, Goshen, IN 46526, June 14, 1996.

*Manufactured Housing Reference Guide for State Installation Programs*, Chapter 10, Council of State Administrative Agencies (COSAA), Arlington, VA, 1998.

*Permanent Wood Foundation System — Design, Fabrication, and Installation Manual*, National Forest Products Association, 1250 Connecticut Avenue, NW, Washington, DC 20036, 1987.

**E.3 References for Extracts in Informational Sections. (Reserved)**

## Index

Copyright © 2020 National Fire Protection Association. All Rights Reserved.

The copyright in this index is separate and distinct from the copyright in the document that it indexes. The licensing provisions set forth for the document are not applicable to this index. This index may not be reproduced in whole or in part by any means without the express written permission of NFPA.

- | -A-   | -F-  |
|---|--|
| <p><b>Administration, Chap. 1</b></p> <ul style="list-style-type: none"> <li>Application, 1.3               <ul style="list-style-type: none"> <li>Flood Hazard Areas, 1.3.6                   <ul style="list-style-type: none"> <li>Pre-Installation Considerations, 1.3.6.1, A.1.3.6.1</li> </ul> </li> </ul> </li> <li>Equivalency, 1.6               <ul style="list-style-type: none"> <li>Appeal, 1.6.8</li> <li>Approval, 1.6.6</li> <li>Approval of Alternatives, 1.6.2</li> <li>General, 1.6.1</li> <li>Permitted Alternatives, 1.6.3</li> <li>Standards, 1.6.4</li> <li>Systems, Materials, and Methods, 1.6.5</li> <li>Tests, 1.6.7</li> </ul> </li> <li>Retroactivity, 1.4</li> <li>Scope, 1.1, A.1.1</li> <li>Term Use, 1.5</li> </ul> <p><b>Alteration</b></p> <ul style="list-style-type: none"> <li>Definition, 3.3.1</li> </ul> <p><b>Anchor</b></p> <ul style="list-style-type: none"> <li>Definition, 3.3.2</li> </ul> <p><b>Anchoring Equipment</b></p> <ul style="list-style-type: none"> <li>Definition, 3.3.3</li> </ul> <p><b>Anchoring System</b></p> <ul style="list-style-type: none"> <li>Definition, 3.3.4</li> </ul> <p><b>Approved</b></p> <ul style="list-style-type: none"> <li>Definition, 3.2.1, A.3.2.1</li> </ul> <p><b>Arid</b></p> <ul style="list-style-type: none"> <li>Definition, 3.3.5</li> </ul> <p><b>Authority Having Jurisdiction (AHJ)</b></p> <ul style="list-style-type: none"> <li>Definition, 3.2.2, A.3.2.2</li> </ul> | <p><b>Final Inspection Checklist, Annex B</b></p> <p><b>Flood</b></p> <ul style="list-style-type: none"> <li>Base Flood               <ul style="list-style-type: none"> <li>Definition, 3.3.9.1</li> </ul> </li> <li>Definition, 3.3.9</li> <li>Design Flood               <ul style="list-style-type: none"> <li>Definition, 3.3.9.2</li> </ul> </li> </ul> <p><b>Flood Damage-Resistant Material</b></p> <ul style="list-style-type: none"> <li>Definition, 3.3.10</li> </ul> <p><b>Flood Hazard Area</b></p> <ul style="list-style-type: none"> <li>Definition, 3.3.11, A.3.3.11</li> </ul> <p><b>Flood Hazard Map</b></p> <ul style="list-style-type: none"> <li>Definition, 3.3.12</li> </ul> <p><b>Footing</b></p> <ul style="list-style-type: none"> <li>Definition, 3.3.13</li> </ul> <p><b>Foundation Wall</b></p> <ul style="list-style-type: none"> <li>Definition, 3.3.14, A.3.3.14</li> </ul> <p><b>Foundations, Chap. 6</b></p> <ul style="list-style-type: none"> <li>Footings, 6.3               <ul style="list-style-type: none"> <li>Acceptable Types of Footings, 6.3.1                   <ul style="list-style-type: none"> <li>ABS Footing Pads, 6.3.1.3</li> <li>Concrete, 6.3.1.1                       <ul style="list-style-type: none"> <li>Pressure-Treated Permanent Wood, 6.3.1.2</li> </ul> </li> <li>Combination Systems, 6.3.4, A.6.3.4</li> </ul> </li> <li>Placement in Freezing Climates, 6.3.2                   <ul style="list-style-type: none"> <li>Conventional Footings, 6.3.2.1</li> <li>Floating Slab Systems, 6.3.2.2</li> <li>Insulated Foundations, 6.3.2.3, A.6.3.2.3</li> </ul> </li> <li>Sizing of Footings, 6.3.3, A.6.3.3</li> </ul> </li> <li>General, 6.1               <ul style="list-style-type: none"> <li>Flood Hazard Areas, 6.1.3</li> <li>Seismic Design Categories D0, D1, D2, and E, 6.1.4</li> </ul> </li> <li>Permanent Foundations, 6.4</li> <li>Piers, 6.2               <ul style="list-style-type: none"> <li>Acceptable Piers— Materials Specification, 6.2.2</li> <li>Design Procedures for Concrete Block Piers, 6.2.4                   <ul style="list-style-type: none"> <li>Elevated Homes, 6.2.4.4</li> <li>Piers 36 in. (915 mm) to 80 in. (2030 mm) High and Corner Piers, 6.2.4.2                       <ul style="list-style-type: none"> <li>Piers Less Than 36 in. (915 mm) High, 6.2.4.1</li> <li>Piers over 80 in. (2030 mm) High, 6.2.4.3</li> </ul> </li> </ul> </li> <li>Design Requirements, 6.2.3                   <ul style="list-style-type: none"> <li>Clearance Under Homes, 6.2.3.3</li> <li>Configuration, 6.2.3.2                       <ul style="list-style-type: none"> <li>Caps, 6.2.3.2.2</li> <li>Concrete Blocks, 6.2.3.2.1                           <ul style="list-style-type: none"> <li>Gaps, 6.2.3.2.3</li> </ul> </li> <li>Pier Heights, 6.2.3.2.4</li> </ul> </li> <li>Load-Bearing Capacity, 6.2.3.1</li> </ul> </li> </ul> </li> </ul> |
| <p style="text-align: center;">-C-</p> <p><b>Crossovers</b></p> <ul style="list-style-type: none"> <li>Definition, 3.3.6, A.3.3.6</li> </ul>  |  |
| <p style="text-align: center;">-D-</p> <p><b>Definitions, Chap. 3</b></p> <p><b>Dwelling Unit</b></p> <ul style="list-style-type: none"> <li>Definition, 3.3.7</li> </ul>   |  |
| <p style="text-align: center;">-E-</p> <p><b>Elevation</b></p> <ul style="list-style-type: none"> <li>Base Flood Elevation (BFE)               <ul style="list-style-type: none"> <li>Definition, 3.3.8.1</li> </ul> </li> <li>Definition, 3.3.8</li> <li>Design Flood Elevation (DFE)               <ul style="list-style-type: none"> <li>Definition, 3.3.8.2</li> </ul> </li> </ul> <p><b>Explanatory Material, Annex A</b></p>  |  |

- Pier Capacities, 6.2.3.1.3
  - General, 6.2.1, A.6.2.1
  - Location and Spacing, 6.2.5
    - Multisection Homes, 6.2.5.4, A.6.2.5.4
    - Perimeter Blocking, 6.2.5.5, A.6.2.5.5
    - Single-Section Homes, 6.2.5.3, A.6.2.5.3
  - Special Considerations, 6.5
    - Severe Climatic Conditions, 6.5.1
    - Special Snow Load Conditions, 6.5.2
- G-**
- General, Chap. 4**
  - Alterations, 4.2, A.4.2
  - Data Plate, 4.3, A.4.3
  - Design and Construction, 4.5
    - Combined Design Methods, 4.5.2
    - Design Methods, 4.5.1
      - Engineered Design, 4.5.1.2
        - Equivalency, 4.5.1.3
      - Prescriptive Design, 4.5.1.1
    - Seismic Design, 4.5.3
      - Engineered Design, 4.5.3.3
      - Prescriptive Design, 4.5.3.2
      - Seismic Design Criteria, 4.5.3.1
        - Determination of Seismic Design Category, 4.5.3.1.1
        - SDCA, B, and C, 4.5.3.1.2
        - SDCD0, D1, D2, and E, 4.5.3.1.3
      - Seismic Installation and Equipment Bracing Requirements, 4.5.3.4
  - Installation Considerations, 4.4
    - Home Installation Manual Supplements, 4.4.3
    - Installation Instructions, 4.4.1
    - Utility Schematics, 4.4.2
  - Preinstallation Considerations, 4.1
    - Flood Hazard Areas, 4.1.2
- I-**
- Imminent Danger**
  - Definition, 3.3.15
- Informational References, Annex E**
- Installation**
  - Definition, 3.3.16
- Installation Alteration**
  - Definition, 3.3.17
- Installation in Flood Hazard Areas, Chap. 12**
  - Foundations and Anchoring, 12.3
    - Design Flood Loads and Conditions, 12.3.1
    - Installations in Existing Manufactured Home Parks, 12.3.3
      - Flood Hazard Areas Classified as A Zones, 12.3.3.2
      - Flood Hazard Areas Classified as V Zones, 12.3.3.1
    - Installations in New Manufactured Home Parks, in Expansions to Existing Manufactured Home Parks, or Outside Existing Manufactured Home Parks, 12.3.2
      - Flood Hazard Areas Classified as A Zones, 12.3.2.2
      - Flood Hazard Areas Classified as V Zones, 12.3.2.1
  - General, 12.1, A.12.1
    - Consultation with AHJ and Registered Professionals, 12.1.2, A.12.1.2
    - Special Techniques Required, 12.1.1
      - Elevation, 12.1.1.4
      - Floodways, 12.1.1.6
      - Foundation and Anchoring, 12.1.1.3, A.12.1.1.3
      - Materials, 12.1.1.2, A.12.1.1.2
      - Methods and Practices, 12.1.1.1
      - Multiple Flood Hazard Zones, 12.1.1.5
    - Installation Procedures, 12.4
      - Obstructions and Enclosures Below the Design Flood Elevation, 12.4.2
        - Flood Hazard Areas Classified as A Zones, 12.4.2.2
        - Flood Hazard Areas Classified as V Zones, 12.4.2.1
      - Use of Fill, 12.4.1
    - Lowest Floor Elevation, 12.2
      - Installations in Existing Manufactured Home Parks, 12.2.2, A.12.2.2
      - Installations in New Manufactured Home Parks, in Expansions to Existing Manufactured Home Parks, or Outside Existing Manufactured Home Parks, 12.2.1
        - Flood Hazard Areas Classified as A Zones, 12.2.1.2
        - Flood Hazard Areas Classified as V Zones, 12.2.1.1
      - Lowest Floor Inspection and Elevation Certification, 12.2.3
  - Post-Installation Considerations, 12.5
    - Breakaway Wall Certification, 12.5.4
    - Elevation Certification, 12.5.2, A.12.5.2
    - Flood Opening Certification, 12.5.5
    - Lowest Floor Inspection, 12.5.1
    - V Zone Certification, 12.5.3
  - Preparation of Appliances, 12.6
    - Air Inlets and Outlets, 12.6.2
    - Outside Appliances, 12.6.1
  - Utility Systems, 12.7
- Installation Instructions**
  - Definition, 3.3.18
- Installation Procedures, Chap. 7**
  - Anchoring Instructions, 7.5
    - Normal Installations, 7.5.2, A.7.5.2
      - Number and Location of Anchors, 7.5.2.4
        - Anchor Installation, 7.5.2.4.3
        - Longitudinal Anchorage, 7.5.2.4.2
        - Transverse Anchorage, 7.5.2.4.1
      - Specifications for Tie-Down Straps and Anchors, 7.5.2.3
        - Anchors, 7.5.2.3.1
        - Tie-Down Straps, 7.5.2.3.2
    - Security Against the Wind, 7.5.1
    - Severe Climatic Conditions, 7.5.4
      - Flood Hazard Areas, 7.5.4.3
      - Freezing Climates, 7.5.4.1
        - Severe Wind Zones, 7.5.4.2, A.7.5.4.2
    - Sidewall or Over-the-Roof Straps, 7.5.3
    - Before Moving Manufactured Home to Location, 7.1, A.7.1
    - Crossover Connections for Multisection Manufactured Homes, 7.4
      - Ductwork Crossovers, 7.4.2
      - Utility Crossovers, 7.4.1

Installation Close-Up/Finishing, 7.7  
 Exterior Siding Close-Up, 7.7.2, A.7.7.2  
 Interior Close-Up, 7.7.3  
 Interior Finish, 7.7.5  
 Single and Multisection Exterior and Interior Close-Up, 7.7.1  
 Unfinished Gypsum Wallboard, 7.7.4  
 Bottom Board Repair, 7.7.4.2, A.7.7.4.2  
 Installation of On-Site Structures, 7.6  
 Expanding Rooms, 7.6.3  
 Garages and Carports, 7.6.4  
 Porches, 7.6.5  
 Steps, Stairways, and Landings, 7.6.6  
 Interconnection of Multisection Homes, 7.3, A.7.3  
 Positioning of Home, 7.2, A.7.2

**-L-****Labeled**

Definition, 3.2.3

**Life Safety Features, Chap. 11**

Carbon Monoxide Detectors, 11.3  
 Fire Separation Distances, 11.4  
 Fire Sprinkler Systems, 11.2  
 Smoke Alarms, 11.1

**Listed**

Definition, 3.2.4, A.3.2.4

**Lowest Floor**

Definition, 3.3.19, A.3.3.19

**-M-****Manufactured Home**

Definition, 3.3.20  
 New Manufactured Home  
 Definition, 3.3.20.1

**Manufactured Home Accessory Building or Structure**

Definition, 3.3.21, A.3.3.21

**Manufactured Home Gas Supply Connector**

Definition, 3.3.22

**Manufactured Home Park or Subdivision**

Definition, 3.3.23  
 Existing Manufactured Home Park or Subdivision  
 Definition, 3.3.23.1  
 New Manufactured Home Park or Subdivision  
 Definition, 3.3.23.2

**Manufactured Home Site**

Definition, 3.3.24

**-P-****Pier**

Definition, 3.3.25, A.3.3.25

**Preparation of Appliances, Chap. 9**

Clothes Dryer Vent, 9.1, A.9.1  
 Comfort Cooling Systems, 9.2, A.9.2  
 Air Conditioners, 9.2.1  
 A-Coil Units, 9.2.1.3  
 Circuit Rating, 9.2.1.2, A.9.2.1.2  
 Evaporative Coolers, 9.2.3  
 Heat Pumps, 9.2.2

Fireplace and Wood-Stove Chimneys and Air Inlets, 9.3  
 Combustion Air Duct Inlets, 9.3.7, A.9.3.7  
 Minimum Extensions Above Roof, 9.3.5, A.9.3.5  
 Required Components, 9.3.6

Flood Hazard Areas, 9.5

Range, Cooktop, and Oven Venting, 9.4

Seismic Design Categories D0, D1, D2, and E, 9.6

**Prescriptive Flood Provision Designs, Chap. 15**

Anchorage and Support Materials, 15.2

General Limitations, 15.3

Prescriptive Foundation Wall Support and Anchorage Systems, 15.5, A.15.5

Footings, 15.5.5

Piers, 15.5.4

Specific Limitations— Foundation Wall Support and Anchorage Systems, 15.5.1

Prescriptive Ground Anchor Support and Anchorage System, 15.4

Footings, 15.4.5

Longitudinal Anchorage, 15.4.3

Piers, 15.4.4

Specific Limitation — Ground Anchor Support and Anchorage System, 15.4.1

Transverse Anchorage, 15.4.2

Scope, 15.1, A.15.1

**-R-****Ramada**

Definition, 3.3.26

**Referenced Publications, Chap. 2****-S-**

Sample Checklist for AHJ Officials, Annex C

Sample Schedule for Manufactured Home Installation Permits, Annex D

**Seismic Installation and Equipment Bracing Requirements, Chap. 14**

General, 14.1

Site-Installed Equipment, 14.3

Site-Installed Water Heaters, 14.2

Utility Attachments, 14.4

**Seismic Provisions for Prescriptive Design of Support Systems, Chap. 13**

Minimum Prescriptive Support System Requirements, 13.2

Prescriptive Foundation Wall Support Systems, 13.4

Prescriptive Pier Support Systems, 13.3

Prescriptive Wood Cripple Wall Support Systems, 13.5

Scope, 13.1

**Shall**

Definition, 3.2.5

**Should**

Definition, 3.2.6

**Site Preparation, Chap. 5**

Access for Transporter, 5.1

Drainage, 5.7

Drainage Structures, 5.7.3

Gutters and Downspouts, 5.7.4

Purpose, 5.7.1

Sloped Site Considerations, 5.7.2, A.5.7.2  
 Encroachments and Setback Distances, 5.2  
 Fire Separation Distance, 5.3  
 Ground Moisture Control, 5.8  
 Acceptable Types of Ground Cover, 5.8.2  
 Proper Installation, 5.8.3  
 Vapor Retarder, 5.8.1  
 Investigation and Bearing Capacity of Soil, 5.6  
 Expansive Soils. [5000:36.3.3], 5.6.3  
 Presumptive Capacities, 5.6.1, A.5.6.1  
 Soil Investigation, 5.6.2  
 Issuance of Permits, 5.4  
 Site Preparation, 5.5  
**Site-Installed Features, Chap. 8**  
 Awnings and Ramadas, 8.4  
 Garden and Bay Windows, 8.3  
 Hinged Roofs and Eaves, 8.2, A.8.2  
 Installation of Site-Installed Features, 8.1  
 Joints and Seams, 8.10  
 Miscellaneous Lights and Fixtures, 8.5  
 Ceiling Fans, 8.5.6  
 Exterior Lights, 8.5.5  
 Grounding Fixtures, 8.5.2  
 Siding, 8.5.4  
 Optional Panels, Siding, and Molding, 8.7  
 Skirting, 8.8  
 Construction, 8.8.1, A.8.8.1  
 Ventilation, 8.8.2  
 Telephone and Cable TV, 8.9, A.8.9  
 Ventilation Options, 8.6, A.8.6  
**Skirting**  
 Definition, 3.3.27  
**Stabilizing Devices**  
 Definition, 3.3.28  
**Standard**  
 Definition, 3.2.7  
**Structure**  
 Definition, 3.3.29  
**Substantial Damage**  
 Definition, 3.3.30  
**Substantial Improvement**  
 Definition, 3.3.31  
**Support System**  
 Definition, 3.3.32

-T-

**Tie**

Definition, 3.3.33  
**Diagonal Tie**  
 Definition, 3.3.33.1  
**Vertical Tie**  
 Definition, 3.3.33.2

-U-

**Utility Connection**

Definition, 3.3.34

**Utility System Connection and Testing, Chap. 10**

**Drainage System, 10.3**  
 Assembly and Support, 10.3.1  
 Connector Sizes, 10.3.3  
 Crossovers, 10.3.4  
 Proper Slopes, 10.3.2  
 Testing Procedures, 10.3.5  
**Electricity, 10.6, A.10.6**  
 Description and Rating of House Wiring, 10.6.1, A.10.6.1  
 Electrical Equipment/Installations, 10.6.2  
 Testing, 10.6.3  
**Gas Supply, 10.4**  
 Connection Procedures, 10.4.6, A.10.4.6  
 Conversion of Gas Appliances, 10.4.1  
 Crossovers, 10.4.4, A.10.4.4  
 Gas Appliance Startup Procedures, 10.4.7  
 Orifices and Regulators, 10.4.2, A.10.4.2  
 Proper Supply Pressure, 10.4.3, A.10.4.3  
 Testing Procedures, 10.4.5  
**Heating Oil Systems, 10.5**  
 Leak Test Procedure, 10.5.5  
 Tank Installation Requirements, 10.5.4  
**Proper Procedures, 10.1**  
**Water Supply, 10.2**  
 Connection Procedures, 10.2.2  
 Crossovers, 10.2.2.2  
 Mandatory Shutoff Valve, 10.2.2.1  
 Fire Sprinkler Systems, 10.2.5  
 Freezing Protection, 10.2.3  
 Necessity, 10.2.3.1  
 Use of Pipe Heating Cable, 10.2.3.2, A.10.2.3.2  
 Maximum Supply Pressure and Reduction, 10.2.1  
 Testing Procedures, 10.2.4